



Immingham Green Energy Terminal

TR030008

Volume 6

6.5 Outline Construction Environmental Management Plan

Planning Act 2008

Regulation 5(2)(a)

Infrastructure Planning (Applications: Prescribed
Forms and Procedure) Regulations 2009 (as
amended)

July 2024

Infrastructure Planning

Planning Act 2008

The Infrastructure Planning (Applications: Prescribed Forms and Procedure) Regulations 2009 (as amended)

Immingham Green Energy Terminal Development Consent Order 2023

6.5 Outline Construction Environmental Management Plan

Regulation Reference	APFP Regulation 5(2)(a)
Planning Inspectorate Case Reference	TR030008
Application Document Reference	TR030008/APP/6.5
Author	Associated British Ports Air Products BR

Version	Date	Status of Version
Version 1	21 September 2023	DCO Application
Version 2	26 March 2024	Deadline 2
Version 3	3 May 2024	Change Application, Deadline 3
Version 4	4 June 2024	Deadline 4
Version 5	26 June 2024	Further Change Application

Version 6	11 July 2024	Deadline 5
-----------	--------------	------------

Table of contents

Chapter	Page
Introduction	2
1.1 Overview	2
1.2 The Applicant	5
1.3 Air Products BR Ltd.....	5
1.4 The Project.....	5
1.5 Construction Activities	7
1.6 Project Site Description	7
1.7 Marine Parameters.....	8
Construction Phase	11
2.1 Construction Programme	11
2.2 Construction Laydown and Welfare Facilities.....	11
2.3 Working Hours.....	12
2.4 Traffic Management	13
2.5 Parking Provision	13
2.6 Wheel Cleaning Facility.....	14
2.7 Site Lighting	14
2.8 Recycling and Disposal of Waste	14
2.9 Best Practice Measures	15
2.10 Soil Management	15
2.11 Cable Installation.....	15
2.12 Training	15
Impact Avoidance and Mitigation Measures Implementation Plan	16
3.1 Management and Mitigation Plan	16
3.2 Implementation and Operation	93
Monitoring	94
4.2 Records.....	96
References	98
Appendix A: Outline Site Waste Management Plan	100
Appendix B: Outline Soils Management Plan	138
Appendix C: Outline Dust Management Plan	164
Appendix D: Outline Reptile Precautionary Working Method Statement	180
Appendix E: Outline Asbestos Management Plan	188
Appendix F: Outline Water Vole Precautionary Working Method Statement	207
Appendix G: Outline Badger Precautionary Working Method Statement	214

Tables

Table 1: Parameters for Work No. 1a	9
Table 2: Indicative Construction Phasing Timeline for Associated Development.....	11
Table 3: Air Quality	16
Table 4: Noise and Vibration.....	18
Table 5: Nature Conservation (Terrestrial Ecology)	25
Table 6: Nature Conservation (Marine Ecology)	41
Table 7: Ornithology	48
Table 8: Traffic and Transport.....	52
Table 9: Marine Transport and Navigation.....	53
Table 10: Landscape and Visual Impact.....	58
Table 11: Historic Environment (Terrestrial)	59
Table 12: Historic Environment (Marine).....	61
Table 13: Physical Processes.....	63
Table 14: Marine Water and Sediment Quality	64
Table 15: Water Quality, Coastal Protection, Flood Risk and Drainage.....	66
Table 16: Climate Change	76
Table 17: Materials and Waste	79
Table 18: Ground Conditions and Land Quality	80
Table 19: Major Accidents and Disasters.....	87
Table 20: Socio-Economics	91
Table 21: Monitoring Requirements	94

Executive Summary

This Outline Construction Environmental Management Plan (“CEMP”) accompanies a proposed application (‘the Application’) to be made by ABP to the Secretary of State (“SoS”) for Transport, seeking development consent to construct, operate and maintain the Immingham Green Energy Terminal. The Terminal would facilitate the import and export of liquid bulks associated with the energy sector and is supported by associated development on the landside.

Subject to the grant of consent for the Project by the SoS, Final CEMPs (including relevant supporting plans) will be provided in relation to relevant parts of the Project in accordance with the measures contained within this Outline CEMP following the appointment of the contractor(s), as set out in the **draft Development Consent Order (“DCO”) [REP4-004]**.

This Outline CEMP sets out a series of proposed measures that would be applied by the contractor through compliance with the Final CEMP(s) to provide effective planning, management and control during construction to mitigate the impacts and effects of the construction of the Project on people, businesses, and the natural and historic environment.

The main part of the Outline CEMP is **Section 3**, which comprises the ‘Impact Avoidance and Mitigation Measures Implementation Plan’. This presents a Register of Environmental Actions and Commitments (“REAC”) for each environmental topic assessed within the Environmental Impact Assessment (“EIA”). Each table sets out the mitigation and management measures to be included as a minimum within the Final CEMP. It also sets out, where relevant, whether monitoring is required and identifies the responsible party for each mitigation/enhancement measure or monitoring requirement.

Introduction

1.1 Overview

- 1.1.1 This CEMP has been prepared by AECOM Ltd (“AECOM”) on behalf of Associated British Ports (“ABP”) (“the Applicant”). It accompanies a proposed application (‘the Application’) to be made to the SoS for Transport, seeking Development Consent to construct, operate and maintain a multi-user green energy terminal to facilitate the import and export of bulk liquids associated with the energy sector, together with associated development on the landside.
- 1.1.2 The Terminal would be operated by ABP and would consist of a jetty and associated landside infrastructure (including jetty access ramp), loading/unloading infrastructure, and pipelines, which would be located on land and in the marine area on the eastern side of the Port of Immingham (“the Port”). These elements alongside the landside associated development are collectively termed “the Project” and the land on which the Project is to be constructed is termed “the Site”. A substantive part of the associated development is for the first user of the Terminal and comprises the construction and operation of a green hydrogen production facility. Air Products (BR) Limited (Air Products) will build and operate the green hydrogen production facility to produce green hydrogen from imported green ammonia.
- 1.1.3 Subject to the grant of consent for the Project by the SoS, Final CEMPs (including relevant supporting plans) will be provided in relation to relevant parts of the Project in accordance with the measures contained in this Outline CEMP following the appointment of the contractor(s), as set out in the **draft DCO [REP4-004]**. The Final CEMPs must be approved by North East Lincolnshire Council (“NELC”), or, in the case of the Final CEMP for the marine aspects of Work No.1, by the Marine Management Organisation (“MMO”). More than one Final CEMP (including its appendices, as relevant) may be submitted and approved under the Draft DCO so as to facilitate the Project coming forward as individual Works (as defined in Schedule 1 of the **draft DCO [REP4-004]**) or brought forward in phases. For example it is envisaged that a separate Final CEMP (including relevant supporting plans) for the marine works (the majority of **Work No. 1**) will be produced and approved separately from the Final CEMP(s) for relevant phases of the terrestrial works.
- 1.1.4 This Outline CEMP sets out a series of proposed measures that would be applied by the contractor through compliance with the Final CEMP(s) to provide effective planning, management and control during construction to mitigate the impacts and effects of the construction of the Project on people, businesses, and the natural and historic environment.
- 1.1.5 The **draft DCO [REP4-004]** requires works undertaken to construct the Project to be in accordance with the Final CEMP(s). The purpose of this is to control construction activities so as to minimise, as far as reasonably practicable, impacts on the environment. This would include implementing industry best practice measures and Project-specific measures, as set out in this Outline

CEMP. The **draft DCO [REP4-004]** ensures that the contractor's Final CEMP(s) is in accordance with the principles set out in the Outline CEMP.

- 1.1.6 The likely significant environmental effects of the Project have been identified through the EIA process and are reported in the Environmental Statement ("ES"). The standard or best practice mitigation and construction management and control measures accounted for in the EIA process, as presented within the ES, will be implemented during construction of the Project. This Outline CEMP explains how these commitments will be implemented and sets out the monitoring and auditing activities to be undertaken to demonstrate that such mitigation and measures are carried out and are effective.
- 1.1.7 The structure of this Outline CEMP is as follows:
- a. **Section 0** introduces the Outline CEMP, the Project and the Applicant.
 - b. **Section 0** sets out the construction programme, working hours, traffic management protocols, site lighting, recycling requirements, and best practice measures.
 - c. **Section 0** presents additional information to be included under each sub-section within the Final CEMP, which includes:
 - i. Impacts and effects identified throughout the EIA process.
 - ii. Mitigation and enhancement measures to be delivered, where the ES has assumed the measure would be applied in the detailed design or construction phase of the Project.
 - iii. The responsible person who will deliver the mitigation and enhancement measures.
- 1.1.8 The following secondary outline management plans and working method statements are appended to this Outline CEMP and final versions are proposed to be appended to the Final CEMP:
- a. Appendix A: Outline Site Waste Management Plan
 - b. Appendix B: Outline Soils Management Plan
 - c. Appendix C: Outline Dust Management Plan
 - d. Appendix D: Outline Reptile Precautionary Working Method Statement
 - e. Appendix E: Outline Asbestos Management Plan
 - f. Appendix F: Outline Water Vole Precautionary Working Method Statement
 - g. Appendix G: Outline Badger Precautionary Working Method Statement
- 1.1.9 The following final secondary management plans and working method statements will be prepared and incorporated into the Final CEMP:
- a. **Arboricultural Method Statement:** to assess the final impact of the Project based on the detailed design. This will set out the phasing of site operations, the finalised tree protection measures for the Site and provide detail on how sensitive elements of work are to be achieved in proximity to retained trees.

The method statement will follow the working techniques set out within **Appendix 8.F: Arboricultural Impact Assessment [APP-185]**.

- b. **Materials Management Plan (“MMP”)**: A written MMP in compliance with the provisions of the CL:AIRE Definition of Waste Code of Practice (“DoW CoP”) demonstrating that material has been deposited in an appropriate manner and will not pose an unacceptable risk to human health or the environment will be produced and finalised at the design and planning stage of the Project and incorporated into the Final CEMP. Once the DCO has been granted, a completed MMP will be submitted to a Qualified Person for approval and issue of a declaration (made under the CL:AIRE DoW CoP), the declaration will be approved by CL:AIRE and submitted to the Environment Agency for its records, before any works to which the MMP relates commence.
- c. **Water Management Plan (“WMP”)**: to include measures necessary to avoid, prevent and reduce adverse effects where possible upon the local surface water environment. This will include steps to remove the risk of damage to water assets.
- d. **Soil Resource Plan**: A written strategy for the management of soil during the works at the Site would be prepared and would detail the arrangements for areas where soil material would be stripped and stored before being returned to its original location or reused elsewhere on the Site.
- e. **Asbestos Management Plan**: An Asbestos Management Plan will be prepared and implemented in accordance with the Outline Asbestos Management Plan (**Appendix E** to this **Outline CEMP**) as part of the final CEMP should asbestos or asbestos containing materials be encountered during the ground investigation.

1.1.10 The DCO application is supported by a number of other management plans, which, in addition to this OCEMP, outline proposed mitigation and management measures that would be adhered to in order to mitigate the impacts and effects of the Project on people, businesses and the natural and historic environment. These management plans are secured by Requirements in the **draft DCO [REP4-004]**:

- a. **Outline Construction Traffic Management Plan (“CTMP”) [REP4-010]**.
- b. **Outline Construction Worker Travel Plan (“CWTP”) (Appendix A** to the CTMP).
- c. **Draft Woodland Compensation Plan [REP4-031]**.
- d. **Outline Landscape and Ecology Management Plan [REP4-012]**.

1.1.11 The DCO application is also supported by an **Outline Marine Archaeological Written Scheme of Investigation (“WSI”) [APP-204]** for the marine aspects of Work No. 1. The final WSI is secured by a Condition in the Draft Marine Licence.

1.2 The Applicant

- 1.2.1 ABP was established in 1981 following the privatisation of the British Transport Docks Board. It is the largest ports group in the UK, owning and operating 21 ports and other transport-related businesses across England, Wales and Scotland.
- 1.2.2 On the Humber, ABP owns and operates four ports, namely the Port and the ports of Hull, Grimsby and Goole, which together constitute the largest ports complex in the UK. The Port is the largest and busiest of ABP's four Humber ports.
- 1.2.3 ABP's statutory undertaking at Immingham, the 'statutory port estate', covers some 480 hectares (ha). The majority of the port estate falls within the administrative boundary of NELC, although the western part of the Port falls within the administrative boundary of North Lincolnshire Council ("NLC").
- 1.2.4 The Port comprises a number of discrete operational areas handling a diverse trade base including liquid fuels, solid fuels, ores, and ro-ro freight being handled from existing in-river jetties. These include the Eastern and Western Jetties, the Immingham Oil Terminal, the Immingham Gas Terminal, Immingham Outer Harbour and the Humber International Terminal ("HIT").
- 1.2.5 The Project, if consented, will be located fully within an extended Port of Immingham SHA area where the Applicant is the Statutory Harbour Authority ("SHA"). In this capacity, the Applicant is responsible, with a set of powers and duties which include the management and regulation of the safety of navigation and marine operations in its SHA area.

1.3 Air Products BR Ltd

- 1.3.1 Air Products (BR) Ltd is a world-leading industrial gases company in operation for nearly 80 years, and more than 60 years in the UK and Ireland with over 1000 UK&I employees working across 35 production facilities in addition to a number of hydrogen refuelling stations and hydrogen, nitrogen and oxygen plants. The company develops, engineers, builds, owns and operates some of the world's largest industrial gas projects.

1.4 The Project

- 1.4.1 In summary, the Project would comprise:

- a. The Nationally Significant Infrastructure project ("NSIP"), **Work No. 1**, comprising:

On the marine side, a Terminal for liquid bulks, comprising:

- i A jetty (defined by **Work No. 1a**) including a loading platform, associated dolphins, fenders and walkways, topside infrastructure but not limited to control rooms, marine loading arms, pipe-racks, pipelines and other infrastructure.
- ii A single berth, with a dredged berthing pocket.

- iii Related landside infrastructure including, but not limited to, a jetty access ramp, a flood defence access ramp and works to raise the seawall locally under the jetty access ramp.
- b. Associated Development on the landside, comprising:
 - i. A corridor between the new jetty and Laporte Road which would support a private road (the 'jetty access road'), pipe-racks, pipelines to enable the ammonia import to the East Site, as well as security gates, a security building, a power distribution building and associated utilities – (**Work No. 2**).
 - ii. 'East Site - Ammonia Storage' (**Work No. 3**) on which an ammonia storage tank and related plant including an ammonia tank flare stack would be constructed (**Work No. 3a**) as well as additional buildings (including welfare building, power distribution building and a process instrumentation building), pipe-racks, pipelines, pipes, cable-racks, utilities and other infrastructure.
 - iii. Construction of a culvert (**Work No. 4**) under Laporte Road for pipelines, pipes and cables and other conducting media linking the two parts of the East Site.
 - iv. 'East Site – Hydrogen Production Facility' (**Work No. 5**) on which up to three hydrogen production units and associated plant including flue gas stacks and flare stacks would be constructed (**Work No. 5a**) together with additional buildings (including process control building, power distribution buildings, process instrumentation buildings, analyser shelters), pipe-racks, pipelines, pipes, utilities and other infrastructure.
 - v. Underground pipelines, pipes, cables and other conducting media (**Work No. 6**), between the East and West Sites, for the transfer of ammonia, hydrogen, nitrogen and utilities, with cathodic protection against saline corrosion.
 - vi. 'West Site' (**Work No. 7**) involving the construction of up to three hydrogen production units with associated flue gas stacks and flare stacks and up to four liquefier units (**Work No. 7a** and **Work No. 7b** combined); hydrogen storage tanks, hydrogen trailer filling stations, a hydrogen vent stack and associated process equipment (**Work No. 7c**); and hydrogen vehicle and trailer filling stations, hydrogen compressors and associated process equipment (**Work No. 7d**). Also additional buildings (including but not limited to control room and workshop building, security and visitor building, contractor building, warehouse, driver administration building, safe haven building, electrical substation and metering station, power distribution buildings, process instrumentation buildings, analyser buildings and additional temporary buildings during construction), process and utility plant including cooling towers and pumps, fire water tank, instrument air equipment, pipe-racks, pipelines, pipes, cable-racks, utilities and other infrastructure.
 - vii. Formation of temporary construction and laydown areas on Queens Road (**Work No. 8**) and off Laporte Road (**Work No. 9**).

viii. Temporary removal of street furniture and modification of overhead cables on Kings Road (**Work No. 10**) associated with the transport of large construction components from the Port to the Site.

1.4.2 The Terminal would operate 24 hours a day, seven days a week and 365 days a year. The Terminal would have capacity of approximately 11 million tonnes per annum and so be able to accommodate up to 292 vessel calls per year and it is anticipated that up to 12 of these calls would be associated with the first user's hydrogen production facility. The vessels which make up the remaining 280 calls to the terminal are expected to serve the future carbon capture and storage market and other liquid bulk energy product markets.

1.4.3 Further information on the Project is provided in **Chapter 2: The Project [REP3-022]**. See **Section 2.4** within **Chapter 2: The Project** for further details regarding Work No's which are referenced throughout this document.

1.5 Construction Activities

1.5.1 The approach to Project construction described in the following sections is considered to be representative of a reasonable worst-case scenario of how the Project would be implemented. The approach to construction would be further refined and finalised during the detailed design phase, subject to the granting of the DCO, and inform the production of the Final CEMP.

1.5.2 The main aspects of constructing the Project's marine and landside infrastructure components are detailed in the following sections. Construction of the Project is anticipated to require the following activities:

- a. Installation and use of temporary site facilities and laydown areas comprising fencing, vehicle parking, material storage areas, fuel storage bunds and worksites.
- b. Installation and use of temporary accesses and haul routes, vegetation clearance and soil removal.
- c. Transportation of materials and labour throughout the construction phase.
- d. Potential use of a concrete batching plant.
- e. Ground works.
- f. Piling (land-side and marine-side).
- g. Continuous flight auger piles.
- h. Vibro and percussive piling techniques.
- i. Infrastructure construction activities, routing or services and utilities.
- j. Capital dredge: It has been determined that a capital dredge would be required for the berth. The maximum spatial extent of the dredge is 10,000m². Dredging of up to 4,000m³ of material would be required.

1.6 Project Site Description

1.6.1 The proposed Terminal would extend seawards into the Humber Estuary and the jetty would be located to the east of the existing Immingham Oil Terminal jetty.

This area falls within the boundaries of the Humber Estuary Special Area of Conservation (“SAC”), Special Protection Area (“SPA”) and Ramsar Site, which collectively form the Humber European Marine Site (“EMS”). The indicative site layout for the Project is shown in **Figure 2.3 [REP3-085]** and the parameters for the marine works are defined in **Section 1.7** below.

- 1.6.2 The East Site itself comprises two parcels of land, which are bisected by Laporte Road. The first parcel of land consists of an area of hardstanding to the north of Laporte Road which is currently in use by the Applicant as a storage area. The second parcel of land is a triangular shaped area of brownfield land that is currently covered by gravel and various stockpiles, which is accessed via Queens Road (A1173) and lies to the south of Laporte Road. The Associated Petroleum Terminals works complex is situated to the north/north-east of the East Site, whilst to the south are various industrial facilities. To the west and north-west is the Port and associated industrial facilities and the ‘Immingham Dock East Gate’ Port entry point from Queens Road. To the east of the East Site is the Long Strip woodland.
- 1.6.3 The West Site currently comprises three agricultural fields, which are bounded by linear hedgerows and drainage ditches. An electrical sub-station and a gas-fired power generator installation are situated to the north-west. The north-west and western boundaries of the West Site are defined by Kings Road and the A1173, including the Grimsby to Immingham ‘Cycle Superhighway’ which runs along the A1173 between the Kings Road and Kiln Lane roundabouts. A landfill is located to the south separated by a landscape buffer strip. Queens Road forms the north-eastern boundary of the West Site with a number of residential and commercial properties located within the Site boundary. The east and south-eastern boundary is adjacent to another gas fired power generator installation, a community recycling centre and a large waste gypsum landfill. A short tarmac access road has been constructed from Kings Road into the West Site, associated with an extant planning consent. A series of overhead power cables run across the middle and southern boundaries of the West Site, with a buried mains water and a buried high-pressure gas pipeline present along the southern boundary. The existing utilities, as currently known, and how these will be protected during construction are detailed within the **Utilities Statement [APP-239]**.
- 1.6.4 A proposed underground Pipeline Corridor connects the West Site to the East Site and extends to the terminal. It runs through an area that has been impacted by industrial development alongside Queens Road and Laporte Road, and also crosses the Grimsby Docks Branch Line.
- 1.6.5 Underground gas mains, water mains and overhead electricity transmission infrastructure cross the Site.

1.7 Marine Parameters

- 1.7.1 The parts of **Work No.1** comprising the approach jetty, the jetty head and loading platform including breasting dolphins and mooring dolphins that lie to the seaward side of the mean high water springs mark will be constructed within the parameters for **Work No.1a** shown on Sheets 1 to 4 of the **Works Plans [REP3-**

012]. The dredge pocket will be located in accordance with the co-ordinates for it provided in a Condition of the Deemed Marine Licence (“DML”) which forms Schedule 3 of the **draft DCO [REP4-004]**. The details that have been used as the basis for the modelling reported in the marine chapters of the ES [**APP-051, APP-054, APP-057, APP-059**] and the **Shadow Habitats Regulation Assessment Report [REP4-014]** are primarily:

- a. The orientation of the jetty, defined by Work No. 1a.
- b. The number of piles and pile diameters (in the marine environment, see **Table 1** below).
- c. The geometry of the dredge pocket. **Table 1** below provides the parameters for the Terminal (Work No. 1a):

Table 1: Parameters for Work No. 1a

Work element	Parameter
Jetty head and related topside infrastructure	Jetty head– up to +13.5m above chart datum Topside infrastructure – up to +35m above chart datum
Mooring dolphins	Up to eight mooring dolphins, four to the east of the jetty head and 4 to the west of the jetty head. Each dolphin up to 13m long and up to 15m wide with a height of up to +13.5m above chart datum
Approach jetty length	Up to 1,200m
Approach jetty height	Up to +13.5m above chart datum
Approach jetty width	Up to 16m wide save for in the location of vehicle passing places where it will be up to 19m wide and in the vicinity of the jetty operations building where it will be up to 29m wide
Pile number and spacing	Approach jetty between point “A” in Sheets 3 and 4 of the Works Plans [REP3-012] and point “B” on Sheet 2 and 3 of the Works Plans [REP3-012] up to 59 piles. Two piles in each row will have a maximum diameter of 1.575m; the remaining piles in the row will have a maximum pile diameter of 1.2m. The pile rows will be spaced at a minimum of 25m (save for the final row at point B as the jetty changes angle where the separation will be less than 25m) and no more than four piles per row (save for the location of the jetty operations building where there will be no more than seven

Work element	Parameter
	<p>per row and vehicle passing places where there will be no more than five per row).</p> <p>Approach jetty between point “B” on Sheets 2 and 3 of the Works Plans [REP3-012] and point “C” on Sheets 1 and 2 of the Works Plans [REP3-012] – up to 156 piles. Two piles in each row will have a maximum diameter of 1.575m; the remaining piles in the row will have a maximum diameter of 1.2m. There will be no more than four piles per row (save for the location of vehicle passing places where there will be no more than five per row).</p> <p>Jetty head and breasting dolphins – up to 104 piles each up to 1.5m diameter.</p> <p>Mooring dolphins – up to 72 piles (each up to 1.5m in diameter) across up to 8 mooring dolphins.</p> <p>Four monopole fenders each up to 2.3m in diameter.</p>

Construction Phase

2.1 Construction Programme

- 2.1.1 There would be a phased approach to the construction of the Project. The construction of the Terminal and first phase of the green hydrogen production facility (including works on both the East Site and West Site as outlined above and described below) would comprise the first phase of development, which, subject to securing the relevant consents, is likely to start in early 2025 and last for between two and a half and three years.
- 2.1.2 Following completion of the first phase of the hydrogen production facility, a further five phases would be constructed incrementally to increase the processing capacity as the market for green hydrogen increases. There could therefore be six phases of development in total.
- 2.1.3 An indicative construction phasing timeline over an indicative eleven-year period is illustrated in **Table 2** and assumes that each phase of the Associated Development would become operational following its construction. Phase 1 represents the peak of construction activity.

Table 2: Indicative Construction Phasing Timeline for Associated Development

Phase	Year 1	Year 2	Year 3	Year 4	Year 5	Year 6	Year 7	Year 8	Year 9	Year 10	Year 11
Phase 1											
Phase 2											
Phase 3											
Phase 4											
Phase 5											
Phase 6											

- 2.1.4 The start of construction of Phase 2 (here shown in Year 4), would depend on a number of factors including market demands for hydrogen at that point in time, whilst the timing of subsequent phases would be subject to the same tests. Construction of Phases 2 – 6 may take up to eight years.

2.2 Construction Laydown and Welfare Facilities

- 2.2.1 Proposed construction laydown areas, including storage, site offices, welfare facilities and car parking, will be located at various places within the Site. **Figure 2.3 [REP3-085]** shows the areas of land that are proposed for construction laydown and contractors' compound(s). Construction laydown areas are required for materials and plant storage and laydown; field-based fabrication and erection of components on-site; siting of concrete batching facilities; vehicle and cycle

parking facilities; and construction offices and construction staff welfare facilities. The construction compound and laydown areas would be secured by security fencing and gates as appropriate.

- 2.2.2 Clearance, levelling and ground preparation works for these laydown areas may be required to provide a suitable surface material. The surface material will be permeable so as to allow rainwater to percolate to ground, with suitably bunded locations identified as storage areas for any hazardous or polluting materials or chemicals to reduce the risk of pollution. This is detailed in **Table 11**.

2.3 Working Hours

- 2.3.1 In months where piling is permitted within the water body spatial, diurnal and duration restrictions apply for certain periods as set out in the DML. For example, it is anticipated that night time restrictions will apply to piling works within the water body, seaward of the mean highwater mark outside the hours of sunrise and sunset¹ in certain summer months (June and August) and between 19:00 and 07:00 in certain winter months (March, September and October), seven days a week. Other marine construction activities including dredging, are assumed to be undertaken on a 24-hour basis and continue until completion for safety or quality reasons.
- 2.3.2 Core landside construction working hours would be between 07:00 and 19:00 Monday to Saturday. However, it is likely that some construction activities may need to be undertaken outside of these core working hours. This is partly because certain construction activities cannot be stopped, such as concrete pouring, but also to manage the construction programme. Where on-site works are to be conducted outside the core hours, they would comply with any restrictions secured in the Requirements or DML or agreed with the local planning authority, in particular regarding control of noise and traffic. The need for any such works would be minimised where possible and would be carefully managed to reduce effects on local people.
- 2.3.3 The following works are permitted outside the hours stated above provided such works do not give rise to any materially new or materially different effects than those assessed in the ES:
- Works that cannot be interrupted, including concrete pours, or that need to be conducted outside of normal work hours for safety reasons, including radiographic testing.
 - Emergency works (any emergency works must be notified to the relevant planning authority within 72 hours of their commencement).

¹ References to sunset and sunrise are, unless otherwise agreed with the MMO, to be in accordance with the relevant daily set and rise times for the British Isles provided by HM Nautical Almanac Office Data

- c. Works that are carried out with the prior approval of the relevant planning authority.
- d. Works necessary to support the construction of **Work No. 1**.
- e. Works that do not exceed maximum permitted levels of noise at each agreed monitoring location to be determined with reference to the ABC Assessment Method for the different working time periods, as set out in BS 5228-1:2009+A1:2014, unless otherwise agreed with the relevant planning authority for specific construction activities.

2.3.4 The capital dredge methodology is anticipated to be backhoe dredge with split hopper barge. The dredger would be sized appropriately to rip the chalk. This would ensure that only one type of dredger would need to be mobilised. Dredge operations would be continuous and operate 24 hours a day and seven days a week.

2.3.5 Construction hours are secured by a Requirement under the **draft DCO [REP4-004]**.

2.4 Traffic Management

2.4.1 It is estimated that the construction workforce, across both the marine and terrestrial construction works, would peak at 919 personnel per day. There would be a total of 1,224 two-way worker trips and 196 HGV trips generated at the peak of construction, to and from the Site.

2.4.2 Construction traffic and the construction workforce are anticipated to travel to the Site via the A180 and A1173. Prior to the start of the construction phase, the contractor would prepare a Final CTMP to control HGV movements, as well as a Final CWTP to control the trips made by the construction workers (including encouraging car sharing) and thus reduce the impact of the workforce upon the highway network. The Final CTMP and CWTP would be based on, and incorporate, the contents and requirements of the **Outline CTMP [REP4-010]** and **Outline CWTP** (which forms Appendix A to the **Outline CTMP**), which form part of the DCO application.

2.4.3 These two plans would set out measures and controls to limit the number of trips on the network in the peak hours, so as to limit the traffic impact of the construction phase as far as possible. Such plans would be implemented for the duration of the Project construction phase.

2.5 Parking Provision

2.5.1 Parking demand will vary throughout the construction phase and parking areas will be set aside within the Site to accommodate parking for construction workers.

2.5.2 It is proposed that sections of the car park will gradually be opened up as construction develops, with a defined number of construction worker car parking spaces to be provided during construction. Managing the number of parking spaces available onsite would help ensure that the number of vehicles is controlled, and that sustainable transport options are promoted. It would be the responsibility of the Travel Plan Co-ordinator (a role required by the CWTP),

working closely with the Site Manager, to determine the number of spaces to be provided.

- 2.5.3 Car parking at the Site would be monitored by the Travel Plan Co-ordinator, with restricted access. The Site Manager and the Travel Plan Co-ordinator will set the appropriate criteria for construction workers to receive a pre-allocated parking space.
- 2.5.4 The Travel Plan Co-ordinator will review the split of vehicles between cars, vans and minibuses, ensuring that the contractor encourages its workers to travel to and from the Site by the sustainable options.

2.6 Wheel Cleaning Facility

- 2.6.1 In the interests of highway safety, wheel cleaning facilities will be installed at the Site from the start of the construction phase. All HGVs will be required to use the wheel wash prior to exiting the Site. The need for this measure and the location of the wheel cleaning facilities will be periodically reviewed throughout the construction phase.

2.7 Site Lighting

- 2.7.1 Construction lighting will be required in areas where natural lighting is unable to reach (sheltered/confined areas) and prior to permanent lighting being installed. Lighting may also be required around the Site for night-time construction and during core working hours within winter months.
- 2.7.2 Artificial lighting would be provided to maintain sufficient security and health and safety for the Site. A **Lighting Assessment** (see **Appendix 2.B [APP-173]**) accompanies the DCO application and outlines measures proposed to avoid excessive glare and minimise spill of light to nearby receptors (including local residents and some ecological receptors) outside of the Site as far as reasonably practicable.
- 2.7.3 Construction temporary lighting will be arranged so that glare is minimised outside the construction site. Lighting will be designed so as not to cause a nuisance outside of the Site in relation to views from residential receptors or light disturbance to ecological receptors.
- 2.7.4 A Lighting Management Plan ("LMP") will be incorporated into the Final CEMP that addresses use and monitoring of lighting, particularly around sensitive areas. The LMP will follow the principles set out within the **Lighting Assessment** (see **Appendix 2.B [APP-173]**).

2.8 Recycling and Disposal of Waste

- 2.8.1 In order to manage and monitor waste, including any spoil generated on-site, an **Outline Site Waste Management Plan ("OSWMP")** is included as **Appendix A** to this Outline CEMP, setting out how waste streams would need to be estimated and monitored and goals set with regards to the waste produced. The Final CEMP would be required to incorporate the principles of the OSWMP as appropriate. The contractor will minimise the creation of waste, maximise the use

of recycled materials and assist the collection, separation, sorting, recycling and recovery of waste arisings, as far as reasonably practicable.

- 2.8.2 The contractor will be required to segregate waste streams on-site, prior to them being taken to a waste facility for recycling or disposal. All waste removal from the Site would be undertaken by licensed waste carriers and taken to licensed waste facilities.

2.9 Best Practice Measures

- 2.9.1 Construction industry guidance (e.g. from the Construction Industry Research and Information Association (“CIRIA”)) will be adopted as far as reasonably practicable to assist in reducing the potential for pollution and nuisance (Ref 4-1). This will be achieved by employing best practice measures.

2.10 Soil Management

- 2.10.1 All soils will be managed in accordance with the Defra Construction Code of Practice for the Sustainable Use of Soil on Development Sites (Ref 4-2) to minimise impacts on soil structure and quality.

- 2.10.2 An **Outline Soils Management Plan** is included within **Appendix B** of this Outline CEMP.

2.11 Cable Installation

- 2.11.1 It will be ensured that worker exposure to any Electric and Magnetic Fields (“EMF”) risks are managed through full compliance with relevant policies and procedures on EMF exposure during any cable installation and commissioning works.

2.12 Training

- 2.12.1 Prior to commencement of construction of Work Nos. 3, 5 or 7 (the “HPF Works”), the Applicant will prepare a Construction Training and Employment Plan relating to the HPF Works which shall set out the Applicant’s strategy for helping local people secure employment opportunities where reasonably practicable in the construction of the HPF Works and shall provide a copy of the plan to NELC for comment. Following commencement of construction of the HPF Works, the Applicant will undertake construction of the HPF Works in accordance with the Construction Training and Employment Plan or such updated plan as the Applicant shall produce and provide to NELC from time to time.

Impact Avoidance and Mitigation Measures Implementation Plan

3.1 Management and Mitigation Plan

- 3.1.1 This section of the Outline CEMP presents a REAC for each environmental topic assessed within the EIA. Each table sets out the mitigation and management measures to be included as a minimum in the Final CEMP. It also illustrates how the monitoring strategy will be set out and the responsible party identified for each mitigation/enhancement measures or monitoring requirement.
- 3.1.2 The Final CEMP would be reviewed, revised and updated as the Project progresses towards construction to ensure all potential impacts and residual effects are considered and addressed as far as practicable, in keeping with available good practice at that point in time.
- 3.1.3 The relevant **Work No's** that each potential impact and mitigation/enhancement measure relates to, as well as the enforcing body for the mitigation/enhancement measures are detailed in **Table 3** to **Table 20** for each technical topic.

Table 3: Air Quality

Potential Impact	Mitigation/Enhancement Measure	Relevant Work Nos	Responsibility	Enforcing body
Construction dust emissions.	<p>The Contractor will develop and implement a Dust Management Plan (“DMP”) in accordance with the Outline Dust Management Plan included as Appendix C of this Outline CEMP.</p> <p>The Plan will adopt a range of industry standard good practice construction phase dust mitigation and monitoring measures, and general control measures, relating to:</p> <p>a. Dust management;</p>	<p>Terrestrial aspect of Work No. 1 and Work No's 2 - 10 (inclusive)</p> <p>Dust is not expected to be</p>	Contractor and Travel Plan Co-Ordinator	NELC

Potential Impact	Mitigation/Enhancement Measure	Relevant Work Nos	Responsibility	Enforcing body
	<p>b. General and Project specific construction activities; and</p> <p>c. Community liaison and complaints procedure.</p> <p>These measures will be applied during all works undertaken based on the level of construction dust risk at sensitive receptors identified in Chapter 6: Air Quality [APP-048].</p>	generated in marine environment		
<p>Emissions from non-road mobile machinery and site plant.</p> <p>Marine vessel emissions.</p> <p>Road traffic emissions.</p>	<p>It is best practice to mitigate emissions to air. Measures to reduce emissions from construction phase vessel and road traffic emissions sources include taking steps to:</p> <p>a) Prohibit unnecessary vehicle or vessel movements;</p> <p>b) Prohibit unnecessary idling of vehicle and vessel engines;</p> <p>c) Encourage/promote the use of cleaner engines and fuel, noting that construction vessels will be required to comply with the MARPOL Regulations; and</p> <p>d) Discourage single-user car journeys.</p>	All Work No's	Contractor	<p>NELC Highways Department</p> <p>Maritime and Coastguard Agency (for marine aspects of Work No. 1)</p>

Table 4: Noise and Vibration

Potential Impact	Mitigation/Enhancement Measure	Relevant Work Nos	Responsibility	Enforcing body
Construction noise and construction traffic noise at nearby Noise Sensitive Receptors (NSR).	<p>Construction noise levels are likely to vary during different construction phases, depending on the location of work sites and proximity to Noise Sensitive Receptors (“NSRs”). The nearest residential NSRs to the Site Boundary are on Queens Road (NSRs 1 and 2) and on the eastern edge of Immingham (NSRs 3 and 4). Based on the current ambient available noise levels at monitoring locations in both of these areas and the BS 5228 ABC category guidance in Table 7.3 of Chapter 7: Noise and Vibration of the ES [APP-049], construction noise limits based upon the measured data are:</p> <p>NSR1 and NSR2 – representative of residential NSRs on Queens Road:</p> <ul style="list-style-type: none"> a) 75 dB LAeq,12hr during daytime. b) 65 dB LAeq,12hr during evening and weekends. c) 55 dB LAeq, 8hr during the night-time. <p>NSR3 and NSR 4 – residential NSRs on the eastern edge of Immingham:</p> <ul style="list-style-type: none"> a) 65 dB LAeq, 12hr during daytime. b) 55 dB LAeq, 12hr during evening and weekends. c) 50 dB LAeq, 8hr during the night-time. 	Work No. 7	Contractor	NELC

Potential Impact	Mitigation/Enhancement Measure	Relevant Work Nos	Responsibility	Enforcing body
[Construction vibration at nearby Noise Sensitive Receptors]	² Construction vibration levels are likely to vary during different construction phases, depending on the location of work sites and proximity to Noise Sensitive Receptors ("NSRs"). The nearest residential NSRs to the Site Boundary are on Queens Road (NSRs 1 and 2) and on the eastern edge of Immingham (NSRs 3 and 4). If driven piling takes place on Work No. 7, a vibration limit of 0.9 mm/s will apply to residential properties on Queens Road (if NSRs 1 or 2 remain in residential use at the relevant time).]	[Work No. 7]	[Contractor]	[NELC]
Construction noise and vibration impacts associated with activities on-site, during construction.	Where on-site construction works are to be conducted outside the core hours, they would comply with any restrictions agreed with the local planning authority. Any such works would be minimised and be carefully managed to reduce effects on local people. Measures to mitigate noise and vibration would be implemented during the construction phase in order to minimise impacts at local NSRs, particularly with respect to any activities required outside of core working hours. Mitigation to be included in the Final CEMP will include, but not be limited to:	All Work No's	Contractor	NELC for terrestrial aspects MMO for marine aspects

² [Material added associated with Proposed Further Change Application – to be removed if change not accepted]

Potential Impact	Mitigation/Enhancement Measure	Relevant Work Nos	Responsibility	Enforcing body
	<ul style="list-style-type: none"> a) Ensuring that processes are in place to minimise noise and vibration before works begin and ensuring that best practical means (“BPM”) are being achieved throughout the construction programme, including the use of localised screening around the main noise producing plant and activities. b) All contractors will be familiar with current legislation and the guidance in BS 5228 (Parts 1 and 2) (Ref 4-4, Ref 4-5), which will be a prerequisite of their appointment. c) Ensuring that modern plant is used, complying with applicable UK noise emission requirements, and selection of inherently quiet plant where possible. d) All pneumatic percussive tools will be provided with effective silencers/acoustic covers. e) Acoustic covers to engines will be kept closed when the engines are in use and idling. 			

Potential Impact	Mitigation/Enhancement Measure	Relevant Work Nos	Responsibility	Enforcing body
	<p>f) ³[Acoustic shrouds are to be fitted to all terrestrial driven piling rigs.]</p> <p>g) Hydraulic techniques for breaking to be used, where practical, in preference to percussive techniques where reasonably practicable.</p> <p>h) ⁴[No driven piling activities are to be undertaken on Saturday afternoons (between 13:00-19:00) in Work No. 7 near to NSRs 1 and 2 (if NSRs 1 or 2 remain in residential use at the relevant time).]</p> <p>i) ⁵[Use of a driven piling exclusion zone: assuming that a driven piling rig (with the assessed nominal hammer energy of 110,000 J) is required for the works, driven piling would not take place at distances of less than 215 m from relevant residential receptors on</p>			

³ [Material added associated with Proposed Further Change Application – to be removed if change not accepted]

⁴ [Material added associated with Proposed Further Change Application – to be removed if change not accepted]

⁵ [Material added associated with Proposed Further Change Application – to be removed if change not accepted]

Potential Impact	Mitigation/Enhancement Measure	Relevant Work Nos	Responsibility	Enforcing body
	<p>Queens Road (NSRs 1 and 2) (which are occupied and in residential use).]</p> <p>j) ⁶[Use of a driven piling rig with a lower nominal hammer energy value than 110,000 J: A piling rig with a low hammer energy value of 1500 J would allow driven piling to occur beyond a distance of approximately 45 m from the residential receptors on Queens Road.]</p> <p>k) ⁷[Use of low vibration CFA/rotary bored/cast in-situ piling methods: this method will be used in closer proximity to the residential receptors, if the above mitigation options preclude the use of driven piling (i.e. the vibration limit of 0.9mm/s at residential NSRs on Queens Road (which remain in residential use) cannot otherwise be achieved).]</p> <p>l) No start-up or shut down of vibratory rollers near to receptors.</p> <p>m) Off-site pre-fabrication for components of the Project, where reasonably practicable.</p>			

⁶ [Material added associated with Proposed Further Change Application – to be removed if change not accepted]

⁷ [Material added associated with Proposed Further Change Application – to be removed if change not accepted]

Potential Impact	Mitigation/Enhancement Measure	Relevant Work Nos	Responsibility	Enforcing body
	<ul style="list-style-type: none"> n) All plant and equipment being used for the works to be properly maintained, silenced where appropriate, operated to prevent excessive noise and vibration and switched off when not in use. o) Machines such as cranes that may be in intermittent use will be shut down between work periods or would be throttled down to a minimum. Machines will not be left running unnecessarily. p) Where reasonably practicable, the contractor will use quieter working methods, the most suitable plant and, reasonable hours of working for noisy operations. q) Where possible, the noisiest items of plant will be located the furthest distance from the nearby NSRs. Plant known to emit noise strongly in one direction will, when possible, be orientated so that the noise is directed away from NSRs. r) Loading and unloading of vehicles, dismantling of site equipment such as scaffolding or moving equipment or materials within the Site to be conducted in such a manner as to minimise noise and vibration generation, as far as reasonably practicable. s) No employees, subcontractors and persons employed on the Site will cause unnecessary noise from their activities e.g. excessive 'revving' of vehicle engines, shouting and other noisy behaviour. No radios or other audio equipment will be allowed on site. 			

Potential Impact	Mitigation/Enhancement Measure	Relevant Work Nos	Responsibility	Enforcing body
	<p>t) Electrically powered plant will be used over diesel power generators where possible and feasible.</p> <p>u) Audible warning systems (including reversing alarms) will be switched to the minimum setting required by the Health and Safety Executive.</p> <p>v) Any tannoy system on site will be used for emergency use only.</p> <p>w) All contractor communication devices will be used at a minimum audible level.</p> <p>x) Appropriate routing of construction traffic on public roads and along access tracks, to reduce construction traffic noise, as far as reasonably practicable (see Outline CTMP [REP4-010]).</p> <p>y) Provision of information to NELC and local residents to advise of potential noisy works that are due to take place.</p> <p>z) Monitoring of noise and vibration complaints and reporting to the contractor for immediate investigation.</p> <p>Regular communication with the local community throughout the construction period will also serve to publicise the works schedule, giving notification to residents regarding periods when higher levels of noise and vibration may occur during specific operations, and providing lines of communication where complaints can be addressed.</p>			

Potential Impact	Mitigation/Enhancement Measure	Relevant Work Nos	Responsibility	Enforcing body
	The need for monitoring of noise levels during construction will be determined through the detailed assessment undertaken in the Final CEMP.			

Table 5: Nature Conservation (Terrestrial Ecology)

Potential Impact	Mitigation/Enhancement Measure	Relevant Work Nos	Responsibility	Enforcing body
Any impacts on terrestrial habitats	<p>All Impacts</p> <p>Measures to be followed for the prevention of surface and ground water pollution, fugitive dust management and noise prevention or amelioration are set out below:</p> <p>a) An Environmental or Ecological Clerk of Works (“ECoW”) will be present during construction as appropriate to oversee implementation of impact avoidance commitments.</p> <p>b) Precautionary working methods would be adopted to manage any residual risk of protected species being encountered e.g. reptiles and badger, and a Precautionary Working Method Statement (“PWMS”) will be prepared as part of the Final CEMP. These measures would include staged removal of potentially suitable vegetation under the supervision of an ecologist, and the covering of excavations overnight to prevent animals becoming trapped.</p>	<p>Terrestrial aspect of Work No. 1 and Work Nos. 2 – 10 (inclusive)</p>	Contractor and ECoW	NELC

Potential Impact	Mitigation/Enhancement Measure	Relevant Work Nos	Responsibility	Enforcing body
	<p>c) All necessary protected species licences would be applied for and obtained prior to undertaking any works that might result in offences under the relevant legislation.</p> <p>d) Precautionary measures will be implemented to prevent trapping wildlife in construction excavations, in order to ensure compliance with animal welfare legislation. Any excavations would be covered overnight, or where this is not practicable, a means of escape would be fitted (e.g. battered soil slope or scaffold plank situated at or below a 45 degree angle), to allow animals (e.g. otter, badger, hedgehog, amphibians) to vacate excavations should they fall in. Where excavations have to be left uncovered over night they would be checked for presence of animals prior to infilling.</p> <p>e) Construction temporary lighting will be arranged so that glare would be minimised outside the construction site. Measures to minimise the impact of construction lighting would be detailed in the Final CEMP.</p> <p>f) Vegetation that may support nesting birds will be removed outside the breeding bird season (avoiding the period March to August inclusive), where possible, for compliance with the Wildlife and Countryside Act 1981 (as amended). Where this is not possible, pre-clearance nest checks by an ECoW will be undertaken. Where active and occupied nests are identified, an appropriate buffer zone will be established around the nest site and the nest monitored until any young have fledged. The ECoW will advise on an appropriate exclusion zone.</p>			

Potential Impact	Mitigation/Enhancement Measure	Relevant Work Nos	Responsibility	Enforcing body
	Typical minimum exclusion zones are 5m for tree/hedge nesting birds and 10-20 m for ground nesting birds (not including Schedule 1 birds).			
Loss of woodland habitat and bat roosts in Long Strip.	<p>Where mature trees within the Long Strip woodland with low bat roost potential would be impacted and cannot reasonably be avoided, trees will be soft-felled under ECoW supervision.</p> <p>Any trees to be removed that support confirmed bat roosts, following completion of emergence surveys in summer 2023, will be removed under the supervision of an ecologist holding a Bat Low Impact Class Licence from Natural England. This is on the basis that the woodland is likely to only support, at most, up to three 'low conservation status' roosts (i.e. feeding, day, night and transitional roosts) based on the very low numbers of bats recorded during walked transects undertaken over spring, summer and autumn 2022, and therefore tree removal would fall within the remit of a Low Impact Class Licence.</p> <p>In the event that a higher number of confirmed roost trees, and/ or the roosts are not considered to be low conservation status, then a European Protected Species Mitigation ("EPSM") derogation licence would be obtained from Natural England.</p> <p>Felled material to be retained for the creation of habitat log piles within retained woodland as set out in the Draft Woodland Compensation Plan [REP4-031].</p> <p>Appropriate root protection zones around retained trees to be implemented as identified on the Tree Protection Plan (see Appendix</p>	Terrestrial aspect of Work No. 1 and Work No. 2	Contractor and ECoW	NELC and Natural England

Potential Impact	Mitigation/Enhancement Measure	Relevant Work Nos	Responsibility	Enforcing body
	8.F: Arboricultural Impact Assessment [APP-185] must be fully respected and their location and significance is to be highlighted to all site staff and contractors during the formal site briefing.			
Damage/ loss of habitat supporting water vole	<p>Vegetation clearance prior to the commencement of culvert construction on Ditch 5 (Work No. 1), which is confirmed to support water voles, will require a Natural England licence (Figure 2 of Appendix 8.D: Otter and Water Vole Survey Report [APP-183]).</p> <p>Given that the length of bank from which water vole would be displaced for the Project (within Work No. 1) is less than 50m, mitigation through a Water Vole Class Licence approach will be adopted for the construction phase; this requires sensitive timing of vegetation clearance to achieve natural displacement of water voles through habitat manipulation under the supervision of an ecologist holding a Water Vole Class Licence from Natural England.</p> <p>The mitigation approach would require appropriate seasonal timing of habitat clearance works to displace water voles prior to damage/ destruction of habitats within Ditch 5, and as such initial vegetation clearance works would be limited to the period 15 February to 15 April and/or 15 September to 31 October. Subsequent works to maintain the cleared area can be undertaken after this initial seasonally restricted clearance period to ensure the habitats remain unsuitable for water vole prior to the commencement of construction. Construction works to the ditch would not be seasonally constrained following the completion of the initial vegetation clearance works under the Class Licence, assuming the banks are maintained as unsuitable for water vole in the period between</p>	Terrestrial aspect of Work No. 1 and Work No. 9	Contractor and ECoW	Natural England

Potential Impact	Mitigation/Enhancement Measure	Relevant Work Nos	Responsibility	Enforcing body
	<p>the initial clearance and the commencement of construction activities at this location.</p> <p>A demarked buffer zone (minimum 10m) would be established between temporary construction compound (Work No. 9) and the adjacent water course (North Beck Drain) which supports water voles.</p> <p>No fenced exclusions or translocations of water voles are proposed.</p> <p>A draft PWMS for water vole is included as Appendix F to this Outline CEMP, and a final version will be prepared, by the Contractor, as part of the Final CEMP.</p>			
Potential damage to/ loss of reptile habitat	<p>The low risk of presence of grass snake on the main drain at the foot of the flood embankment (Ditch 5 in Work No. 1) would be addressed through a precautionary approach where a staged strip of bankside vegetation is undertaken to encourage natural dispersal of any reptiles that may be present.</p> <p>A draft PWMS for reptiles is included as Appendix G of this Outline CEMP, and a final version will be prepared, by the Contractor, as part of the Final CEMP.</p>	Terrestrial aspect of Work No. 1	Contractor and ECoW	NELC
Potential damage to/ loss of badger sett(s)	<p>Pre-clearance checks of any habitats that may conceal badger setts that were not identified during surveys for the Project will be undertaken. In the event that badger setts are discovered and damage/ disturbance</p>	Work No's 2 and 3	Contractor and ECoW	Natural England

Potential Impact	Mitigation/Enhancement Measure	Relevant Work Nos	Responsibility	Enforcing body
	<p>cannot be avoided, a licence will be obtained from Natural England to close the sett within the seasonal period (June to November inclusive)</p> <p>A draft PWMS for badger is included as Appendix H of this Outline CEMP, and a final version will be prepared, by the Contractor, as part of the Final CEMP.</p>			
Loss of/ damage to woodland and trees	<p>Where trees are to be retained within the Site Boundary, for example in the Long Strip woodland, any tree surgery recommendations contained within Appendix 8.F Arboricultural Impact Assessment [APP-185] would be undertaken in accordance with BS3998:2010 Tree work – Recommendations by suitably qualified and insured contractors.</p> <p>All construction site facilities including site huts, staff and contractor parking and areas for storage will be located outside of the root protection area (“RPA”) or crown spread of retained trees, including those not specifically covered in Appendix 8.F: Arboricultural Impact Assessment [APP-185]. Space is likely to be constrained on the Site and will need to be carefully considered. The Construction Exclusion Zones identified on the Tree Protection Plan (see Appendix 8.F: Arboricultural Impact Assessment [APP-185]) must be fully respected and their location and significance is to be highlighted to all site staff and contractors during the formal site briefing.</p> <p>The use, mixing and washing of materials can lead to run off or inadvertent spillage into tree root zones. Many substances often used on construction sites can be toxic to tree roots (such as concrete, fuels, salts, builders sand and herbicides) and can result in the death of tree roots and</p>	<p>Terrestrial aspect of Work No. 1 and Work Nos. 2 – 10 (inclusive)</p>	Contractor and ECoW	NELC

Potential Impact	Mitigation/Enhancement Measure	Relevant Work Nos	Responsibility	Enforcing body
	<p>beneficial soil organisms and can have a significant impact on the future health and appearance of the tree.</p> <p>The storage of materials and any washing, mixing or refuelling will take place in agreed allocated areas at least 5m from the edge of the RPA of retained trees.</p> <p>All necessary protective fencing would be installed prior to the commencement of any site clearance or construction works.</p> <p>Any slope effect must be taken into account and where there is a potential for run off, heavy duty polythene sheeting and sandbags must be in place as bunding to prevent toxic materials reaching Root Protection Areas (“RPAs”).</p> <p>Particular care is required where high sided vehicles, long reach machinery and plant with jibs, booms and counterweights are to operate with in proximity to retained trees. A banksman will be used where the movement of plant or long reach machinery occurs within 5m of any part of a retained tree to ensure no damage is sustained.</p> <p>The advice of a suitably qualified engineer must be obtained to inform any potential issue of heave.</p> <p>Ground protection will be installed within the RPAs, specified to the highest expected load and installed in accordance with the Outline Tree</p>			

Potential Impact	Mitigation/Enhancement Measure	Relevant Work Nos	Responsibility	Enforcing body
	<p>Protection Measures included within Annex E of Appendix 8.F: Arboricultural Impact Assessment [APP-185].</p> <p>In addition, T414 will require an outer RPA incursion to facilitate the construction of a new access road and a footway. The access road will only require a very minor RPA incursion and prior to its construction a trench is to be excavated by hand (using compressed air and a soil vacuum where available) under the supervision of an Arboriculturist to a depth of 1m along the outermost extent of the proposed footprint for the new road and edging within the RPA. Roots will be carefully exposed and severed with a clean sharp tool to leave a clean cut end (set back 200mm from the edge of the excavation). Root pruning will be timed to avoid times of high physiological activity for the tree (e.g. in winter or late summer avoiding periods of drought) and will be supervised by an Arboriculturist.</p> <p>Installation of the footway must follow 'no dig' principles to avoid adverse effects to the structure of the soil and excavation which would require root severance. This can be achieved with the use of a three dimensional load bearing surface (such as Cellweb, ArborRaft or equivalent) that is designed to meet the highest expected loads and is positioned on top of the existing ground level.</p> <p>This methodology will increase the final level of the hard surfacing and this must be taken into consideration.</p> <p>Edging is often not required to stabilise the load bearing surface and the edge of the surface. If edging is required, this must be installed without</p>			

Potential Impact	Mitigation/Enhancement Measure	Relevant Work Nos	Responsibility	Enforcing body
	<p>excavation and can be cast directly onto the load bearing surface with any uncured concrete contained within impermeable sheeting to prevent leaching into the RPA.</p> <p>These works must be supervised by an Arboriculturist and will not negatively impact the physiological or structural condition of the tree.</p> <p>A tree condition survey would be undertaken by a competent Arboriculturist immediately following the tree removal works within the Long Strip woodland to identify any safety risks to the Site. Following this a periodic inspection regime will be implemented and an initial tree condition survey would be undertaken one month following the commencement of site works and then six monthly for the first two years. After the first two years the Arboriculturist will advise on the recommended frequency of surveys.</p> <p>The suitability for pollarding or coppicing would be assessed by a walkover of the Site by the Site Arboriculturist and agreed with the NELC Tree Officer prior to the commencement of site works.</p> <p>An Arboricultural Method Statement will be developed as part of the detailed design. Issues to be addressed by the method statement:</p> <p>a) Summary of the final arboricultural impacts related to the detailed design.</p>			

Potential Impact	Mitigation/Enhancement Measure	Relevant Work Nos	Responsibility	Enforcing body
	<ul style="list-style-type: none"> b) Pre commencement meeting, site briefing and assessment of trees to be removed by an arboriculturist for their suitability for tree pruning. c) Order and phasing of operations. d) Site supervision and monitoring of implementation. e) Tree works and confirmation of the final extent of tree loss. f) Tree protection fencing. g) Ground protection. h) Site storage and facilities. i) Movement of people, plant and materials. j) Enabling works. k) Installation of new surfacing. l) Installation of new structures. m) Installation of new services and/or diversion of existing services. n) Hard landscaping. 			

Potential Impact	Mitigation/Enhancement Measure	Relevant Work Nos	Responsibility	Enforcing body
	<p>o) Soft Landscaping.</p> <p>p) Removal of tree protection measures.</p> <p><u>Tree Planting</u></p> <p>Existing areas of unsurfaced ground must be protected during the demolition and construction phases if they are to be re-used for new plantings. Protection can be achieved using fit for purpose ground protection measures as set out in BS5837:2012 Section 6.2.3 or by creating a fenced exclusion zone. Where protection is not feasible, soil amelioration or replacement works will be required to ensure suitable growing conditions for new trees to fully establish.</p> <p>Where new trees are to be planted, the minimum planting distances detailed in Annex A of Appendix 8.F: Arboricultural Impact Assessment [APP-185], Table A.1 of BS5837:2012 must be adhered to, to prevent direct damage to services and structures from future tree growth.</p> <p>New tree planting would be implemented in accordance with the guidance set out in BS8545: 2014 Trees: from nursery to establishment in the landscape – Recommendations.</p> <p><u>Services</u></p>			

Potential Impact	Mitigation/Enhancement Measure	Relevant Work Nos	Responsibility	Enforcing body
	<p>Where services must be routed within the RPA of a retained tree this process will be subject to a detailed method statement with approval from the Planning Authority.</p> <p>The principles of the National Joint Utilities Group (“NJUG”) Volume 4 (Ref 4-26) guidance must be adhered to.</p> <p>All services would be bundled as far as possible and installed within RPAs using hand/compressed air excavation (e.g. for shallow service runs) or trenchless techniques such as impact moling (thrust boring) with all access pits and inspection chambers being located outside of the RPA. The route would run as far from the main stem of a retained tree as possible and would be at a minimum depth so that the upper 2m of the soil profile is undisturbed. The depth of the run may need to be adjusted to account for soil type and species variation and this would be determined subject to the advice of an arboriculturist.</p> <p>Any water pipes would be constructed so as to be resistant to ingress by tree roots (both existing trees, and newly planted trees) which would include the use of root barriers where appropriate.</p> <p><u>Outline Tree Protection Measures</u></p> <p>The default position as set out by BS 5837:2012 is that retained trees must be protected from construction operations with the erection of robust protective fencing positioned on the outer edge of the RPA or crown spread (whichever is greatest). All site operations will be restricted to the area outside of tree protection fencing and this area will form a</p>			

Potential Impact	Mitigation/Enhancement Measure	Relevant Work Nos	Responsibility	Enforcing body
	<p>Construction Exclusion Zone (“CEZ”) unless agreed otherwise. Protection measures will be installed as set out in the Tree Protection Plan included as Annex D of Appendix 8.F: Arboricultural Impact Assessment [APP-185].</p> <p>The area inside the fence and any additional tree protection measures will be sacrosanct and must not be removed or altered without the prior approval of an arboriculturist. Any damage to tree protection measures must be reported immediately.</p> <p>Fencing shall be constructed with robust vertical and horizontal scaffold framework with weldmesh panels firmly attached as per BS 5837:2012 Figure 7. Vertical support poles and bracing poles must be located with care to avoid underground utility services and will be sited to avoid the structural roots of retained trees.</p> <p>Alternative equivalent robust and immovable fencing specification including site hoarding will also be appropriate.</p> <p>Suitable all weather signage will be fixed to fencing to notify site staff and visitors of the construction exclusion zone and its purpose.</p> <p>When entering and exiting the Site, the fencing contractor must avoid the production of ruts on the unprotected surface of the ground.</p>			

Potential Impact	Mitigation/Enhancement Measure	Relevant Work Nos	Responsibility	Enforcing body
	<p>Protective fencing and ground protection shall stay in place until all development operations have been completed and the prior consent of the project arboriculturist has been obtained.</p> <p>Should access be unavoidable within the RPA of a retained tree, fit for purpose ground protection must be in place which is sufficient to protect the structure of the soil from damage based on the heaviest anticipated load.</p> <p>As set out in section 6.2.3.3 of BS5837:2012 the following ground protection measures will be appropriate:</p> <ul style="list-style-type: none"> a. Suitable ground protection for pedestrian only access will comprise a single thickness of scaffold boards set on a compressible layer of 100mm of woodchip on a geotextile separation layer. b. Pedestrian operated plant up to two tonnes in weight would require the use of a proprietary ground protection system (such as Ground Guards or Eve Trakway or equivalent) set on a minimum depth of 150mm woodchip or sharp sand. c. Heavier loads will require ground protection to an engineering specification in conjunction with arboricultural advice. <p>As a guide the threshold beyond which root development is significantly affected is a bulk density ranging from 1.4g per cm³ for clay soils, to 1.75g per cm³ for sandy soils.</p>			

Potential Impact	Mitigation/Enhancement Measure	Relevant Work Nos	Responsibility	Enforcing body
	<p>Tree protective measures shall stay in place until all construction operations are completed, and removal is agreed with the project arboriculturist.</p> <p>Excavation must only take place within the RPA of a retained tree with the prior agreement of the project arboriculturist. All excavation must be undertaken using hand tools or compressed air (such as an air spade).</p> <p>The following general principles will apply:</p> <ol style="list-style-type: none"> a. Individual or small groups of roots less than 25mm in diameter will be retained where possible but can be severed with a sharp tool such as secateurs or pruning saws to leave a clean cut end (ideally 100mm back from the face of the excavation to account for future regrowth) where they pose an obstruction. b. Where roots are encountered which are larger than 25mm in diameter or where significant groups of smaller roots are found, the advice of an arboriculturist must be sought to decide an appropriate course of action. c. Roots must only be exposed for the minimum period possible. In the interim period any exposed roots must be completely covered with dampened hessian sacking (which may require ongoing re wetting) to avoid drying out and exposure to light (which can result in the death of roots). Backfill for excavations would utilise the parent material and must not be significantly compacted. 			

Potential Impact	Mitigation/Enhancement Measure	Relevant Work Nos	Responsibility	Enforcing body
	<p>The storage of materials and any washing, mixing or refuelling must take place in agreed allocated areas at least 5m from the edge of the RPA of retained trees.</p> <p>Any slope effect must be taken into account and where there is a potential for run off, heavy duty polythene sheeting and sandbags must be in place as bunding to prevent toxic materials reaching RPAs.</p> <p>Where works in close proximity to retained trees cannot be practicably avoided, these works would be undertaken in accordance with current best practice at the time of the works as set out within Appendix 8.F: Arboricultural Impact Assessment [APP-185]. In August 2023, current best practice is defined in:</p> <ul style="list-style-type: none"> a. British Standard (BS) 5837: 2012 Trees in relation to design, demolition and construction – Recommendations. b. British Standard (BS) 3998: 2010 Treework – Recommendations. c. National Joint Utilities Group (NJUG) Guidelines for the Planning, Installation and Maintenance of Utility Apparatus in Proximity to Trees. <p>All tree works recommended as a result of the preliminary tree survey of the Site which considered trees in the context of the current use of the Site (these works are included as preliminary management recommendations in the Tree Schedule in Annex B of Appendix 8.F:</p>			

Potential Impact	Mitigation/Enhancement Measure	Relevant Work Nos	Responsibility	Enforcing body
	Arboricultural Impact Assessment [APP-185] should be actioned within the recommended timescales.			

Table 6: Nature Conservation (Marine Ecology)

Potential Impact	Mitigation/Enhancement Measure	Relevant Work Nos	Responsibility	Enforcing body
Any marine impact	Marine Compliance Manager An ABP compliance manager would be put in place who would have over-arching responsibility for year-round compliance with the programme of environmental mitigation.	Marine aspect of Work No. 1	ABP	MMO/ Natural England
Commonly occurring environmental effects	Biosecurity control measures outlined below would be included within the Final CEMP. Preventing a breach in biosecurity: ABP's existing biosecurity management procedures will be followed during construction. Best practice guidance has been developed on how to manage marine biosecurity risks and invasive non-native species (INNS) at sites and when undertaking activities through the preparation and implementation	Marine aspect of Work No. 1	Contractor	MMO

Potential Impact	Mitigation/Enhancement Measure	Relevant Work Nos	Responsibility	Enforcing body
	<p>of biosecurity plans. This has been used to develop measures that will be followed during the dredging process:</p> <p>‘Check, Clean and Dry’ method: Following the ‘Check, Clean and Dry’ method, prior to use, marine construction equipment will be checked for mud, aquatic animals or plant material and anything found will be removed. Equipment will be cleaned thoroughly and allowed to fully dry to kill off any organisms that may have attached. This process will also be undertaken once relevant marine construction activities are completed and before equipment is removed from the site.</p> <p>Hull Cleaning: The hulls of any vessels used during construction will be maintained through regular cleaning to minimise the number of fouling organisms present. Hull cleaning can take place on land or in-water. In both cases, care will be taken to prevent the organisms and coating particles from being released into the water.</p> <p>Protective Coatings: The use of protective coatings on any vessels used during construction will be employed to reduce the fouling of the vessel’s hull and other below-water surfaces. These coatings usually contain a toxic chemical (such as copper) or an irritant (such as pepper) that discourages organisms from attaching. Other coatings, such as those that are silicone-based, provide a surface that is more difficult to adhere to firmly, making cleaning of the hull less laborious. The type and concentration of coatings that can be applied to a boat hull is regulated and can vary between countries.</p>			

Potential Impact	Mitigation/Enhancement Measure	Relevant Work Nos	Responsibility	Enforcing body
Impacts on fish and marine mammals resulting from underwater noise and vibration	The gradual increase of marine piling power, incrementally, until full operational power is achieved will be used as part of the marine piling methodology. This will give fish and marine mammals the opportunity to move away from the area before the onset of full impact strikes. The duration of the soft start would be at least 20 minutes in line with the JNCC marine piling protocol (Ref 4-6).	Marine aspect of Work No. 1	Contractor	MMO
	Vibro piling will be used where possible which produces lower peak source noise levels than percussive piling (although it is recognised that impact marine piling is anticipated to always be required to reach the required design depths).	Marine aspect of Work No. 1	Contractor	MMO
	Seasonal piling restrictions will be placed on marine piling as follows: <ul style="list-style-type: none"> 1. No marine piling is to take place within the waterbody between 1 April and 31 May inclusive in any calendar year. This will minimise the potential impact on the greatest number of different migratory fish in the Humber Estuary in accordance with the periods identified in Table 9.15 of Chapter 9: Nature Conservation (Marine Ecology) of the ES [APP-051] and also the more vulnerable earlier life stages of a number of migratory fish species. This restriction will not apply to marine piling that can be undertaken outside the waterbody at periods of low water. 2. The duration of percussive marine piling is to be restricted within the waterbody from 1 June to 30 June and 1 August to 31 October inclusive in any year to minimise the impacts on fish migrating through the Humber Estuary during this period such as silver eels, 	Marine aspect of Work No. 1	Contractor	MMO

Potential Impact	Mitigation/Enhancement Measure	Relevant Work Nos	Responsibility	Enforcing body
	<p>river lamprey and returning adult Atlantic salmon. The maximum amount of percussive marine piling permitted within any 24-hour period must not exceed 270 minutes, with an agreed contingency period of an additional 60 minutes within any 24-hour period which can be used in exceptional circumstances (in line with the piling reporting protocol). The measurement of time during each work-block described above must begin at the start of each timeframe, roll throughout it, then cease at the end, where measurement will begin again at the start of the next timeframe, such process to be repeated until the end of marine piling works. This restriction does not apply to percussive marine piling that can be undertaken outside the waterbody at periods of low water.</p>			
	<p>Restrictions will be placed on night time marine piling as follows:</p> <ol style="list-style-type: none"> a. During the periods 1 March to 31 March, 1 June to 30 June and 1 August to 31 October inclusive, piling will be restricted at night. Specifically, no piling will be undertaken from 7 pm to 7 am in March, September and October and between sunset and sunrise in June and August. Marine piling operations that have already been initiated will, however, be completed where an immediate cessation of the activity would form an unsafe working practice. This restriction would not apply to marine piling that can be undertaken outside the waterbody at periods of low water which will limit the potential effects of underwater marine piling noise on the nocturnal movements of river lamprey and glass eels. 	<p>Marine aspect of Work No. 1</p>	<p>Contractor</p>	<p>MMO</p>

Potential Impact	Mitigation/Enhancement Measure	Relevant Work Nos	Responsibility	Enforcing body
	<p>The JNCC Statutory Nature Conservation Agency Protocol for Minimising the Risk of Injury to Marine Mammals During Piling (Ref 4-6) will be followed during percussive marine piling. The key procedures highlighted in this document include the following:</p> <ul style="list-style-type: none"> a. Establishment of a 'mitigation zone' of 500 m from the marine piling locations, prior to any percussive marine piling. Within this mitigation zone, observations of marine mammals would be undertaken by a trained member of the construction team using marine mammal identification resources. b. 30 minutes prior to the commencement of percussive marine piling, a search should be undertaken by the Marine Mammal Observer to determine that no marine mammals are within the mitigation zone. Percussive marine piling activity would not be commenced if marine mammals are detected within the mitigation zone or until 20 minutes after the last visual detection. c. During percussive marine piling, the Marine Mammal Observer would observe the mitigation zone to determine that no marine mammals are within this area. Construction workers will be alerted if marine mammals are identified, and marine piling will cease whilst any marine mammals are within the mitigation zone. Marine piling can recommence when the marine mammal exits the mitigation zone and there is no further detection after 20 minutes. If there is a pause in percussive marine piling operations for any reason over an agreed period of time, then another search (and soft-start procedures for marine piling) would be repeated before 	<p>Marine aspect of Work No. 1</p>	<p>Contractor and marine ECoW</p>	<p>MMO</p>

Potential Impact	Mitigation/Enhancement Measure	Relevant Work Nos	Responsibility	Enforcing body
	<p>activity recommences. If, however, the mitigation zone has been observed while marine piling has ceased and no marine mammals have entered the zone, marine piling activity can recommence immediately.</p>			
	<p>Cumulative seasonal piling restrictions will be placed on percussive marine piling where it is occurring in IGET and IERRT at the same time, as follows:</p> <p>Where piling operations for IERRT and IGET are occurring at the same time a combined percussive piling restriction is proposed for the Project.</p> <p>For the period 1 June to 30 June and 1 August to 31 October inclusive the maximum duration of percussive piling permitted within any four-week period is a total of 196-hours where any percussive pile drivers for either one or both projects are in operation. Where percussive piling is occurring simultaneously across the two projects, these respective time periods will not be double counted as the temporal exposure to this effect is not increased.</p> <p>The measurement of time during each 196-hour work-block must begin at the start of each timeframe, roll throughout it, then cease at the end, where measurement will begin again at the start of the next timeframe, such process to be repeated until the end of piling works. This restriction</p>			

Potential Impact	Mitigation/Enhancement Measure	Relevant Work Nos	Responsibility	Enforcing body
	<p>does not apply to percussive piling that can be undertaken outside of the waterbody at periods of low water.</p> <p>The 196-hours is inclusive of any percussive piling arising from the need to trigger the contingency period from either project.</p> <p>An ABP consents manager will be responsible for overall compliance with this requirement, including the combined reporting, detailing the total duration of piling each day, across the two projects. This will again be communicated to the MMO via the agreed reporting and meeting schedule.</p>			
	<p>A Piling reporting protocol will be adhered to as follows:</p> <p>All marine piling operations will comply with a piling reporting protocol agreed with the MMO and secured under Condition 16 of the Deemed Marine Licence.</p> <p>Weekly reports must be submitted to the MMO on the duration of percussive piling that is undertaken on any given day on which piling takes place during the construction of the authorised development, unless otherwise agreed in writing with the MMO.</p> <p>The reports submitted to the MMO must include a log of the number and approximate location of piling rigs which are in operation on any given day, along with the number of piles driven.</p>	Marine aspect of Work No. 1	Contractor and marine ECoW	MMO

Potential Impact	Mitigation/Enhancement Measure	Relevant Work Nos	Responsibility	Enforcing body
	<p>Fortnightly meetings must be held with the MMO to discuss the weekly reports submitted and agree any corrective action if required, unless otherwise agreed in writing with the MMO.</p> <p>Where percussive piling is paused the recommencement of such percussive piling may take place for a contingency period of up to a total of 60 minutes within any 24-hour period in addition to the otherwise maximum amount of percussive piling permitted within any 24-hour period.</p>			
Impacts on fish from light spill	The jetty decking will be designed to avoid any unnecessary light-spill on the water to avoid disruption or blocking of migratory routes for fish. The jetty decking will be lit for safety and operational purposes.	Marine aspect of Work No 1	Contractor	MMO

Table 7: Ornithology

Potential Impact	Mitigation/Enhancement Measure	Relevant Work Nos	Responsibility	Enforcing body
Impacts to SPA birds	<p>Ecological Clerk of Works</p> <p>An ecological Clerk of Works (ECoW) will be implemented during the overwintering period (October to March inclusive) to ensure the agreed</p>	Marine aspect of Work No. 1	ECoW	MMO/ Natural England

Potential Impact	Mitigation/Enhancement Measure	Relevant Work Nos	Responsibility	Enforcing body
	mitigation measures for the SPA birds are adhered to and that the appropriate guidance can be provided throughout the construction works.			
<p>Direct loss to intertidal feeding and roosting habitat as a result of the piles</p> <p>Direct changes to waterbird foraging habitat as a result of the capital dredge and dredge disposal</p> <p>Indirect changes to foraging and roosting habitat as a result of changes to hydrodynamic and</p>	<p>Additional Mitigation Measures</p> <p><u>Winter marine construction restriction from 1 October to 31 March (approach jetty)</u></p> <p>In order to minimise potential disturbance effects on wintering populations of coastal waterbirds on the foreshore it is proposed that marine construction activity associated with the approach jetty can only be undertaken at distances greater than 200 m of Mean Low Water Springs (“MLWS”) during the period 1 October to 31 March inclusive. This restriction applies until an acoustic barrier/visual screen has been installed on both sides of the semi-completed structure. Construction activity can then be undertaken on the approach jetty itself, behind the screens. The barrier/visual screen will only be required for the period 1 October to 31 March and for sections of the approach jetty within 200m of MLWS. With the addition of acoustic barriers, noise levels on the intertidal mudflat will be less than 70 dB(A) which is the range of existing background noise levels of operational port activities in the Port of Immingham area.</p> <p><u>Noise suppression system (approach jetty)</u></p> <p>It is proposed that a noise suppression system (consisting of a piling sleeve with noise insulating properties) is used during all percussive marine piling activities associated with the approach jetty (during all</p>	Marine aspect of Work No.1	Contractor and ECoW	MMO/ Natural England

Potential Impact	Mitigation/Enhancement Measure	Relevant Work Nos	Responsibility	Enforcing body
<p>sedimentary processes</p> <p>Changes to seabed habitats and species as a result of sediment deposition during piling</p> <p>Airborne noise and visual disturbance to coastal waterbirds using intertidal habitats</p> <p>Airborne noise and visual disturbance to coastal waterbirds using functionally linked terrestrial habitats outside</p>	<p>periods of the year) to reduce noise levels on nearby foreshore areas. The noise suppression system is predicted to reduce noise levels to <70dB Lmax at distances greater than approximately 200m from marine piling and also in the range of existing background noise levels of operational port activities in the Port of Immingham area.</p> <p><u>Soft starts</u></p> <p>Using soft starts (as outlined in Chapter 9: Nature Conservation (Marine Ecology) [APP-051]) will allow birds to become more tolerant to marine piling noise by allowing a more gradual increase in noise levels which will reduce the potential for birds to become startled. This will be applied to all marine piling activity.</p> <p><u>Cold weather construction restriction</u></p> <p>Coastal waterbirds are considered particularly vulnerable to bird disturbance during periods of extreme winter weather. On this basis a temporary cessation of all construction activity within 200 m of Mean Low Water Spring (“MLWS”) would be implemented following seven consecutive days of freezing (zero or sub-zero temperature) weather conditions. The restriction should not be lifted until after 24 hours of above freezing temperatures and also that Metrological Office weather forecasts indicate that freezing conditions will not return for the next five days. Similar measures have been implemented for other nearby developments and also as part of the JNCC scheme to reduce</p>			

Potential Impact	Mitigation/Enhancement Measure	Relevant Work Nos	Responsibility	Enforcing body
<p>the boundary of the Humber Estuary SPA/ Ramsar</p> <p>Noise and visual disturbance during capital dredge disposal</p>	<p>disturbance to waterfowl due to shooting activity during severe winter weather.</p>			
<p>Direct loss of terrestrial habitats that are functionally linked to the Humber Estuary SPA/ Ramsar</p> <p>Direct loss of breeding bird (SPA/ Ramsar) habitats</p> <p>Direct loss of breeding bird (non-SPA/</p>	<p>Standard Mitigation Measures</p> <p><u>Impacts on Nesting Birds (construction)</u></p> <p>Vegetation clearance will be undertaken outside the nesting bird season where possible, and clearance works will be avoided in the period March to August inclusive to ensure compliance with the Wildlife and Countryside Act 1981 (as amended) (Ref 4-7).</p> <p>Where this is not possible, pre-clearance checks of vegetation would be undertaken to identify any nesting species. If occupied nests are identified, an appropriate buffer zone (at least 2m) would be established around the nest to ensure it is protected from damage/ destruction during construction. No clearance of vegetation within the buffer zone would be undertaken until any young had fledged and the nest was confirmed to be unoccupied.</p>	<p>All Work No's</p>	<p>Contractor and ECoW</p>	<p>MMO/ Natural England</p>

Potential Impact	Mitigation/Enhancement Measure	Relevant Work Nos	Responsibility	Enforcing body
Ramsar) habitats				
Loss of Woodland in the Long Strip	A compensation strategy for the loss of woodland (a UK Priority Habitat) will be agreed with NELC pursuant to the draft DCO to ensure compliance with Local Planning Policy 41, which states that the council will seek to “.. <i>minimise the loss of biodiversity features, or where loss is unavoidable and justified ensure appropriate mitigation and compensation measures are provided..</i> ”.	Terrestrial aspect of Work No.1 and Work No. 2	ECoW	NELC pursuant to Requirement 11

Table 8: Traffic and Transport

Potential Impact	Mitigation/Enhancement Measure	Relevant Work Nos	Responsibility	Enforcing body
Traffic impacts of abnormal loads movements across wider road network	<p>Where practicable, the Project would use modularisation to reduce on-site works and maximise the works completed in specialised fabrication facilities off-site. This would require the use of delivery by sea to the Port of Immingham of large prefabricated elements of operational plant and then the use of large HGVs to transport abnormal loads from the Port to the relevant parts of the Site.</p> <p>In addition to the large modules and large equipment items which may be abnormal loads, there will also be other smaller modules and equipment items shipped through the port wherever practicable.</p>	Work No’s 3, 5 and 7	Travel Plan Co-ordinator to oversee management, monitoring and implementation of the individual measures within the CTMP and CWTP.	NELC Highways Department (pursuant to Requirement 7 in respect of the CTMP and CWTP)

Potential Impact	Mitigation/Enhancement Measure	Relevant Work Nos	Responsibility	Enforcing body
			Other responsibilities to be confirmed by the contractor.	

Table 9: Marine Transport and Navigation

Potential Impact	Mitigation/Enhancement Measure	Relevant Work Nos	Responsibility	Enforcing body
<p>C1: Allision of the Project Works Craft with Port Infrastructure</p> <p>C2: Allision of Passing Vessel with the Project Marine Works</p> <p>C3: Collision of Passing Vessel with the Project Works Craft</p>	<p>Standard industry mitigation measures will be followed which are appropriate to the construction and operational activities being undertaken:</p> <p>a. Updated port controls, plans and procedures - existing port documents including the Port Marine Safety Management System (“MSMS”), Humber Passage Plan (“HPP”), and Humber Emergency Plan (“HEP”), will be updated to take into account the Project.</p> <p>b. Vessel Traffic Service (“VTS”) - adherence of vessels to Humber Vessel Traffic Services requirements and instructions. Humber VTS will help control vessel movements and avoid dangerous encounter situations, e.g., involving construction vessels.</p> <p>c. Aids to Navigation (“AtoNs”) - the marine works shall be appropriately lit as soon as there are items which pose a hazard to navigation. Once operational, aids to navigation shall be provided and maintained</p>	Marine aspect of Work No 1	Contractor	MMO & HES (Humber Estuary Services)

Potential Impact	Mitigation/Enhancement Measure	Relevant Work Nos	Responsibility	Enforcing body
<p>C4: Collision of the Project Vessel during Navigation</p> <p>C5: Collision during Towage Operations</p> <p>C6: Increased Collision Risk between other vessels due to Displacement away from the Construction Site</p> <p>C7a: Increased Grounding Risk for Other Vessels due to Displacement from the Project Construction Area</p>	<p>so that the structure and berth can be identified. The safe navigation of all vessels in the Humber is aided by numerous existing AtoNs.</p> <p>d. AIS Equipment - the vast majority of vessels using the Humber broadcast on AIS and therefore can be tracked by other vessels for collision avoidance, as well as by the VTS. The majority of Project vessels, including gas carriers and construction barges, will broadcast on AIS.</p> <p>e. Passage Planning - project vessels will have in place appropriate passage plans as well as adhering to the Humber Passage Plan when applicable.</p> <p>f. COLREGS - vessels will adhere to the Convention on the International Regulations for Preventing Collisions at Sea, 1972 ("COLREGS").</p> <p>g. Availability of secondary channel - there is a secondary channel (Foul Holme) that can be used by certain vessels within a set tidal range.</p> <p>h. Circulation of Information - information will be circulated about the Project to users of the Humber via Notices to Mariners and river warnings broadcast by the VTS every 2 hours (or more frequently if required) which consist of maritime safety information, and designated no-go zones. Temporary construction information not on Admiralty charts would be marked by other means, e.g., Portable Pilot Unit ("PPU").</p>			

Potential Impact	Mitigation/Enhancement Measure	Relevant Work Nos	Responsibility	Enforcing body
<p>C7b: Grounding Risk for the Project Works Craft</p> <p>C8: Payload Related Incidents</p>	<ul style="list-style-type: none"> i. Stakeholder liaison - stakeholder engagement and liaison will be held with recreational and fishing representatives to make them aware of the Project and related vessel activities during the different phases. j. Communications between Project/Port - discussion of upcoming activities shall take place with the personnel at Immingham, HES and where relevant, the Pilots and IOT. k. Hydrographic surveys - the current programme of surveying at the Port of Immingham shall be updated to include the Project. The results of the survey shall be provided to the UKHO for use in navigational charts and compared with previous surveys to inform potential requirements for maintenance dredging. l. Weather limits - the maximum weather limits for operations shall be assessed and set for all activities. These shall be monitored against real time and forecasted weather conditions throughout the construction process. In addition, operational weather limits shall also be considered for vessels using the terminal during the operational phase. m. Weather monitoring - weather forecasting and monitoring shall be carried out and compared with the allowable weather limits for reliable planning and assessment of risk regarding the weather operating limits, which will vary between phases and activities, e.g., construction vs. normal operation. 			

Potential Impact	Mitigation/Enhancement Measure	Relevant Work Nos	Responsibility	Enforcing body
	<p>n. Tidal Limits - tidal limits will apply to certain activities (analogous to weather limits).</p> <p>o. Speed limits - a maximum speed limit of 5 knots will apply to vessels passing the Project Berth (similar to IOT). VTS will monitor for unsafe speeds, including during construction work. Sanctions may be used against repeat offenders, e.g., removal of PEC.</p> <p>p. Emergency plans, exercises and response resources - these will be in place, as appropriate, for each phase. For example, construction contractors shall have tier 1 oil spill response equipment to ensure any pollution events can be contained.</p> <p>q. Approval of tidal works - this is required before any construction activity can commence. This will follow on from a contractor approval process.</p> <p>r. Contractor RAMS and SMS - contractors shall have Risk Assessment Method Statement (RAMS) and Safety Management System (SMS) covering all of the construction activities which shall be reviewed by the Harbour Authority prior to the commencement of activities.</p> <p>s. CDM Regulations - The Construction (Design and Management) Regulations 2015 will be adhered to, to help protect employee health during construction projects.</p>			

Potential Impact	Mitigation/Enhancement Measure	Relevant Work Nos	Responsibility	Enforcing body
	<p>t. Standard Operating Procedures (“SOP”) - suitable procedures will be in place during construction work</p> <p>u. Vessel Checks - checks will be carried out to make sure construction vessels are fit for purpose.</p> <p>v. Non-Routine Towage (“NRT”) Assessments - these will be carried out when necessary to assess the risks and establish requirements, e.g., if pilotage is required, number of tugs, radius of towage, tidal restrictions, etc. Covered in HES Towage Guidelines.</p> <p>w. Designated Point of Contact - during construction activities, there will be a designated PoC to provide appropriate information and respond to emergency situations. This role shall be the main line of communication between the works and the SHA.</p> <p>x. Safety Vessel - a safety vessel will be ready and on standby during construction activities. The availability of a safety vessel in the area of the marine works shall provide for rapid response to emergency situations and an overview of the activity being conducted; during Construction.</p> <p>y. Dropped Object Procedure - a dropped object procedure will be in place to report and respond to any drop incidents.</p>			

Potential Impact	Mitigation/Enhancement Measure	Relevant Work Nos	Responsibility	Enforcing body
	<p>z. Construction Surveys - pre & post-construction surveys will be carried out to confirm that under keel clearance remains unchanged (in case of unreported incidents).</p> <p>aa. Loading/unloading plan - equipment and materials being delivered by barge shall have plans specifying the order and method of loading and unloading at the marine works site.</p>			

Table 10: Landscape and Visual Impact

Potential Impact	Mitigation/Enhancement Measure	Relevant Work Nos	Responsibility	Enforcing body
<p>Visibility of new landscape features.</p> <p>Increased visibility of construction activities and vehicles.</p> <p>Minor loss of scattered scrub, temporary prevention of</p>	<p>Valued trees, woodland, existing vegetation and other landscape features will be retained wherever possible, and will be protected in accordance with BS5837:2012 (Ref 4-8). Trees in relation to design, demolition and construction. During construction trees would be clearly fenced or marked so that site operatives are in no doubt as to which ones are to be kept and protected.</p> <p>Construction temporary lighting will be arranged so that glare would be minimised outside the construction site. Measures to minimise the impact of construction lighting would be detailed in the Final CEMP.</p>	All Work No's	Contractor	<p>NELC for terrestrial aspects</p> <p>MMO for marine aspects</p>

Potential Impact	Mitigation/Enhancement Measure	Relevant Work Nos	Responsibility	Enforcing body
<p>farming of areas of arable farmland, loss of trees within the Long Strip woodland.</p> <p>Introduction of construction lighting.</p>				

Table 11: Historic Environment (Terrestrial)

Potential Impact	Mitigation/Enhancement Measure	Relevant Work Nos	Responsibility	Enforcing body
<p>Impacts on setting of heritage assets.</p> <p>Partial or total removal or truncation of known and/or unknown heritage assets.</p>	<p>Construction methods which will “do no harm” will be employed at two locations within the Project Boundary, specifically:</p> <p>1) Deep Horizontal Directional Drilling (“HDD”) will be utilised to install the main pipeline within the Pipeline Corridor (Work No. 6), which will place the new pipeline below the archaeological horizon in such a manner which does not damage the archaeological horizon. There is a possibility that an additional utility pipeline may need to be installed using a c.1m wide trench cut along the length of the Pipeline Corridor. If remains which are deemed to be significant in nature are encountered during these utility corridor works, the utility works will be halted and the NELC Heritage</p>	<p>Work No’s 2 - 10</p>	<p>Contractor and Archaeologist.</p>	<p>NELC</p>

Potential Impact	Mitigation/Enhancement Measure	Relevant Work Nos	Responsibility	Enforcing body
<p>Compaction of archaeological remains.</p> <p>Changes to local hydrology that could result in the drying out of underlying peat deposits and affect preservation levels of heritage assets.</p> <p>Damage to heritage assets.</p>	<p>officer consulted in order to understand if further works are required in relation to the asset in order to characterise, record and understand it. There are no known heritage assets which will be subject to a significant impact from this work, at this location.</p> <p>2) "No impact" methodologies within the area of the Temporary Construction Area (Work No. 9). Specifically, there will be:</p> <ul style="list-style-type: none"> a. No permanent buildings other than containers and/or storage sheds. b. No foundation or excavation work. c. No topsoil removal. d. ⁸[Provision of 150mm of compacted fill.] e. Ground protection via [geotextile layer] or similar. <p>If remains which are deemed to be significant in nature are encountered during any works, the relevant part of the works will be halted and NELC</p>			

⁸ [Material added associated with Proposed Further Change Application – to be removed if change not accepted]

Potential Impact	Mitigation/Enhancement Measure	Relevant Work Nos	Responsibility	Enforcing body
	Heritage officer consulted in order to understand if further works are required in relation to the asset in order to characterise, record and understand it.			

Table 12: Historic Environment (Marine)

Potential Impact	Mitigation/Enhancement Measure	Relevant Work Nos	Responsibility	Enforcing body
Direct impacts (e.g. physical damage) on known and potential marine cultural heritage receptors and deposits of archaeological importance as a result of construction and capital dredging	<p>Written Scheme of Investigation (WSI)</p> <p>All mitigation measures would be secured through a WSI. An Outline WSI is included as Appendix 15.B [APP-204] of the DCO application. The final WSI will need to take account of any relevant matters emerging through the ongoing detailed design process and any relevant matters emerging through the examination of the DCO application.</p> <p>The following measures will be included in the WSI:</p> <p>Archaeological Exclusion Zones</p> <ol style="list-style-type: none"> As no A1 anomalies have been identified for this assessment, no AEZs are currently recommended for the Project. For any A1 anomalies discovered during the works then this mitigation will be used. A2 anomalies - for anomalies assigned an A2 archaeological classification, especially A2_h anomalies (Appendix 15.A [APP-203]), no AEZs are currently recommended. However, avoidance of these anomalies by micro-siting will be carried out, if possible, if they are directly impacted by the 	Marine aspect of Work No.1	Contractor and Archaeologist	MMO

Potential Impact	Mitigation/Enhancement Measure	Relevant Work Nos	Responsibility	Enforcing body
<p>Indirect impacts to known and potential marine cultural heritage receptors due to altered sediment or hydrological processes</p>	<p>Project. If micro-siting is not possible, then further appraisal and investigation to ascertain the nature of the anomalies would take place.</p> <p>Palaeogeography Geophysical surveys undertaken to support the project design, would be assessed by a suitably qualified archaeological contractor to support baseline enhancement and identification of unknown marine cultural heritage receptors.</p> <p>A geoarchaeological assessment of any future marine borehole logs obtained as part of this detailed design ground investigation will be undertaken, especially in respect of any logs that contain organic deposits for dating purposes. This will aid in refining the interpretation and therefore help determine the archaeological potential of the area.</p> <p>Protocol for Archaeological Discoveries (“PAD”) If previously unknown sites or material are encountered during the different phases of the Project, measures would be taken to reduce the level of impact. In order to provide for these unexpected discoveries a PAD would be adopted. A PAD is a system for reporting and investigating unexpected archaeological discoveries encountered during construction activities, with a Retained Archaeologist providing guidance and advising on the implementation of the PAD.</p>			

Table 13: Physical Processes

Potential Impact	Mitigation/Enhancement Measure	Relevant Work Nos	Responsibility	Enforcing body
<p>Increased SSC and potential sedimentation</p> <p>Changes in seabed bathymetry and composition</p> <p>Changes in local flow speeds (and potential impact on local sediment dynamics)</p> <p>Local changes to hydrodynamic regime (flow speed and direction) & associated local changes to the sediment transport pathways</p> <p>Local changes to the wave regime</p>	<p>Even disposal deposition: The targeting of disposal loads in the central/deeper areas of the disposal sites (HU056 and HU060) will be undertaken to reduce depth reductions. This will minimise the initial reduction in water depth and any environmental changes at these disposal sites</p>	<p>Marine aspect of Work No.1</p>	<p>Contractor</p>	<p>MMO</p>

Potential Impact	Mitigation/Enhancement Measure	Relevant Work Nos	Responsibility	Enforcing body
Potential impacts on existing features, including existing marine infrastructure, outfalls and estuary banks and channels				

Table 14: Marine Water and Sediment Quality

Potential Impact	Mitigation/Enhancement Measure	Relevant Work Nos	Responsibility	Enforcing body
Changes to dissolved oxygen concentrations as a result of increased Suspended Sediment Concentrations (“SSC”) during piling, capital dredging and disposal activities (or during the maintenance	<p>The following guidance will be adopted:</p> <ul style="list-style-type: none"> a. ‘Pollution prevention for businesses’ Guidance in England (Ref 4-11). b. Pollution Prevention Guidance (“PPG”), or Guidance for Pollution Prevention (“GPP”) in the UK (Ref 4-12). <ul style="list-style-type: none"> i. Understanding Your Environmental Responsibilities – Good Environmental Practices (“PPG1”). ii. Works and maintenance in or near water (“GPP5”). 	Marine aspect of Work No.1	Contractor	MMO

Potential Impact	Mitigation/Enhancement Measure	Relevant Work Nos	Responsibility	Enforcing body
<p>dredging and disposal activities)</p> <p>Changes to chemical water quality as a result of potential sediment-bound contaminants being released during piling, capital dredging and disposal activities (or during maintenance dredging and disposal activities);</p> <p>Redistribution of sediment-bound contaminants during piling, capital dredging and disposal activities (or during maintenance dredging and</p>	<ul style="list-style-type: none"> iii. Working at construction and demolition sites (“PPG6”). iv. Safe storage and disposal of used oils (“GPP8”). c. The Oil Care Code. d. CIRIA’s Environmental Good Practice on Site (Ref 4-13). <p>All wastes generated on site will be removed in a timely manner and any materials and containers giving rise to possible spills or contamination of the surrounding environment will be taken from site to be processed at a licensed facility.</p> <p>Liquid oils/chemicals required for use during construction will be stored in suitable containers/bunded storage areas. In the event of a pollution incident measures to report, manage, and minimise any impacts will be pursued, with construction spill response procedures to contain any accidental spills. In addition, an oil spill contingency plan is currently in place for the Port of Immingham to minimise any impacts in the event of a spill entering the water and these measures would also be applicable to the Project. Plant will also be maintained regularly, and spill kits will be available for use in the event of a spill onsite. Refuelling will be in designated areas to limit the potential for spillages. Fuel will be stored in the Site compound overnight, limiting the potential for fuel theft and vandalism which could cause pollution. Should any pollution incidents occur, they will be reported</p>			

Potential Impact	Mitigation/Enhancement Measure	Relevant Work Nos	Responsibility	Enforcing body
disposal activities); and Changes to marine water quality from accidental spillages or leaks during construction	immediately to the relevant authorities. The workforce will be trained in preventing and dealing with pollution incidents.			

Table 15: Water Quality, Coastal Protection, Flood Risk and Drainage

Potential Impact	Mitigation/Enhancement Measure	Relevant Work Nos	Responsibility	Enforcing body
Contamination from suspended solids or other chemical contaminants. Surface water runoff. Chemical spillages or fire.	The Final CEMP will include a Water Management Plan (“WMP”) as a technical appendix. The Final CEMP will be informed by the following Guidance for Pollution Prevention (“GPPs”): a. GPP 1: Understanding your environmental responsibilities – good environmental practices; b. GPP 2: Above ground oil storage;	All Work No’s	Contractor	NELC and Environment Agency for terrestrial aspects MMO for marine aspects

Potential Impact	Mitigation/Enhancement Measure	Relevant Work Nos	Responsibility	Enforcing body
<p>Alteration in fluvial and overland flow paths.</p> <p>Flood risk increase.</p> <p>Increased risk of blockage of drains.</p> <p>Changes in tidal regime.</p> <p>Increase in risk to aquatic life from potential water use and discharges to the environment.</p> <p>Construction works mobilising contamination.</p>	<p>c. GPP 3: Use and design of oil separators in surface water drainage systems;</p> <p>d. GPP 4: Treatment and disposal of wastewater where there is no connection to the public foul sewer;</p> <p>e. GPP 5: Works and maintenance in or near water;</p> <p>f. GPP 8: Safe storage and disposal of used oils;</p> <p>g. GPP 13: Vehicle washing and cleaning;</p> <p>h. GPP 19: Vehicles: Service and Repair;</p> <p>i. GPP 20: Dewatering underground ducts and chambers;</p> <p>j. GPP 21: Pollution Incident Response Plans;</p> <p>k. GPP 22: Dealing with spills; and</p> <p>l. GPP 26: Safe storage – drums and intermediate bulk containers.</p> <p>Construction phase operations would be carried out in accordance with relevant guidance contained within the following PPG:</p> <p>a. PPG6: Working at construction and demolition sites;</p> <p>b. PPG7: Safe storage – the safe operation of refuelling facilities; and</p>			

Potential Impact	Mitigation/Enhancement Measure	Relevant Work Nos	Responsibility	Enforcing body
	<p>c. PPG18: Managing fire water and major spillages.</p> <p>Additional good practice guidance for mitigation to protect the water environment can be found in the following key CIRIA documents and British Standards Institute documents which would inform the Final CEMP:</p> <ul style="list-style-type: none"> a. British Standards Institute (2009) BS6031:2009 Code of Practice for Earth Works. b. British Standards Institute (2013) BS8582 Code of Practice for Surface Water Management of Development Sites. c. C753 (2015) The SuDS Manual (second edition); d. C744 (2015) Coastal and marine environmental site guide (second edition); e. C741 (2015) Environmental good practice on site guide (fourth edition); f. C648 (2006) Control of water pollution from linear construction projects, technical guidance; g. C609 (2004) Sustainable Drainage Systems, hydraulic, structural and water quality advice; and 			

Potential Impact	Mitigation/Enhancement Measure	Relevant Work Nos	Responsibility	Enforcing body
	<p>h. C532 (2001) Control of water pollution from construction sites – Guidance for consultants and contractors.</p> <p>Fine sediment, surface water runoff, flooding and de-watering</p> <p>There are a wide range of measures that can be adopted by the Contractor to reduce the risk of excessive fine sediment in runoff (timing of works, minimising earthworks and seeding or covering them), to intercept runoff to prevent uncontrolled runoff from the Site (e.g. by using cut off drains, fabric silt fences, bunds and straw bales, designated areas for cleaning plant and equipment, wheel washes and road sweepers), and to treat runoff to remove excessive levels of fine sediment (e.g. settlement lagoons, sumps, spraying on to land or even proprietary measures such as lamella clarifiers).</p> <p>Temporary drainage facilities will be provided within the Work No. areas, including the Temporary Construction areas (including around the concrete batching plant in the East Site (Works No.5a)), throughout the construction phases, where necessary, to ensure controlled discharge of surface water run-off. Measures that would be considered for temporary drainage include:</p> <p>a. installation of measures such as swales, silt fences and appropriately sized settlement tanks/ ponds to reduce sediment load;</p>			

Potential Impact	Mitigation/Enhancement Measure	Relevant Work Nos	Responsibility	Enforcing body
	<p>b. cut-off ditches or geotextile silt-fences, installed around excavations, exposed ground and</p> <p>c. stockpiles to prevent uncontrolled release of sediments from the Project;</p> <p>d. Site access points will be regularly cleaned to prevent build-up of dust and mud:</p> <p>e. a valve will be installed to isolate the settlement tank/ ponds in the event of a polluted discharge; and</p> <p>f. oil interceptors to be installed (notably the outflow from the settlement pond/ tank) to reduce the potential risk for contamination of groundwater and surface water.</p> <p>The Contractor would monitor the need for measures depending on the nature of the works being undertaken the weather conditions, and the performance of sustainable drainage systems installed.</p> <p>Best practice guidance and mitigation measures would be implemented to manage the risk of accidental spillages on site and potential conveyance to nearby waterbodies via surface runoff or land drains. These measures would be included in the WMP and adopted during the construction works. Measures would be in accordance with prevailing pollution prevention legislation and follow best practice guidance. They would include details of how fuel and other chemicals (including cement) would be stored, used on site, and equipment and</p>			

Potential Impact	Mitigation/Enhancement Measure	Relevant Work Nos	Responsibility	Enforcing body
	<p>plant cleaned, as well as how leaks and spillages would be prevented or remediated if needed. This would also include the implementation of a Pollution Prevention Plan and an Emergency Response Plan. In addition, any site welfare facilities would be appropriately managed, and all foul waste disposed of by a licensed contractor to a suitably permitted facility. Measures include:</p> <ul style="list-style-type: none"> a. containment measures will be implemented, including drip trays, bunding or double-skinned tanks of fuels and oils; all chemicals will be stored in accordance with their Control of Substances Hazardous to Health (COSHH) guidelines, whilst spill kits will be provided in areas of fuel/ oil storage; b. an Emergency Spillage Plan will be produced, which site staff will have read and understood; c. the mixing and handling of materials will be undertaken in designated areas and away from surface water drains; and d. plant and machinery will be kept away from surface water bodies wherever possible and will have drip trays installed beneath oil tanks/ engines/ gearboxes and hydraulics, which will be checked and emptied regularly. Refuelling and delivery areas will be located away from surface water drains. <p>Temporary Construction Areas for laydown and construction compounds (Work No. 8 and Work No.9) would be suitably enclosed with fencing in order to stop construction plant etc. becoming buoyant</p>			

Potential Impact	Mitigation/Enhancement Measure	Relevant Work Nos	Responsibility	Enforcing body
	<p>and floating away should flooding from a breach or overtopping event occur.</p> <p>Construction materials would be suitably stored in line with best practice and COSHH/COMAH regulations. Siting construction materials in areas of low flood risk where possible and planning works by reference to regularly monitored weather forecasts. In the event of extreme weather and a flood warning being in place construction plant would be removed from the Site for the duration of the flood warning event.</p> <p>During the construction phase, the Contractor would monitor weather forecasts on a monthly, weekly and daily basis, and plan works accordingly. For example, works adjacent to the flood defences, works adjacent to the channel of any watercourse would be avoided or halted were there to be a risk of high flows or even flooding. In addition, the Contractor would sign up to Environment Agency flood warning alerts and produce an Emergency Response Plan which details the actions it would take in the event of a possible flood event. These actions would be hierarchal meaning that as the risk increases the Contractor would implement more stringent protection measures. This is important to ensure all workers, the construction site and third-party land, property and people are adequately protected from flooding during the construction phase.</p> <p>If groundwater is encountered during below ground construction, suitable de-watering methods would be used. A dewatering scheme will be prepared and implemented to manage groundwater arising</p>			

Potential Impact	Mitigation/Enhancement Measure	Relevant Work Nos	Responsibility	Enforcing body
	<p>from the operations and water treatment prior to controlled discharge. Any significant volumes of groundwater dewatering required, dependent on disposal methods, would require an Environmental Permit. Potential for groundwater emergence in excavations would be assessed prior to commencing works on site to establish volumes and points of discharge, and ultimately any residual flood risks.</p> <p>Safe egress and exits would be maintained at all times when working in excavations. When working in excavations a banksman would be present at all times.</p> <p>All construction workers would undergo site induction training prior to being allowed access onto site. This would include instructions on what to do in the event of emergency incidents such as flooding, access and egress routes and the location of safe refuge, if required.</p> <p>As part of the proposed works, the standard of protection afforded by the existing flood defences in proximity to the jetty access road and pipe rack would be increased as the crest height of the defences would be increased to 7m AOD and designed to tie in with the defences along either side.</p> <p>A small area to the south east of the Temporary Construction Area (Work Area 9), adjacent to the watercourse, is located in Flood Zone 2. During the construction phase no temporary buildings, plant or materials will be located within this area of fluvial floodplain to allow storage of flood water should high flows occur on the North Beck.</p>			

Potential Impact	Mitigation/Enhancement Measure	Relevant Work Nos	Responsibility	Enforcing body
	<p>The drainage approach for Temporary Construction Area (Work No. 8) 's surface water and drainage approach would allow for a filter drain system to be installed to collect surface water run-off along the perimeter. The run-off would then be taken to an oil interceptor, silt buster or similar to treat run-off to an acceptable quality level.</p> <p>The ground within Temporary Construction Area (Work No. 9) will be covered with breathable heavy duty ground mat protection to prevent any undue environmental impact. This will allow the Temporary Construction Area to continue to drain at current greenfield runoff rates.</p> <p>The Environment Agency require an 8m clear strip from the landward toe of the fluvial defence along the watercourse to allow for maintenance and access. Any compound or storage area located within the Temporary Construction Area (Work No.9) would therefore be located further than 8m from the landward toe.</p> <p>Continuity of the Tidal Flood Defences</p> <p>During the construction period piling will be located a sufficient distance away from the flood defence and designed so that the defence is not adversely affected. On the landward side, temporary works and contingency measures will be put in place, as necessary, for the construction of the proposed ramps and new section of flood defence to ensure the continuity of the flood defence throughout the works.</p>			

Potential Impact	Mitigation/Enhancement Measure	Relevant Work Nos	Responsibility	Enforcing body
	<p>The contractor will be required to provide a contingency plan for deployable or temporary flood defence works methods, approved by the Environment Agency, prior to the commencement of the works, or through structuring the works in such a way that the existing defence wall can remain in-situ until the new structure is completed.</p> <p>Further information will be provided and consultation with the Environment Agency undertaken when the design and construction method are finalised. Mitigation measures will include a combination of detailed weather forecasting with construction works only undertaken at low tide.</p> <p>The flood defences and any future works to the defences will not be impacted as a result of the Project. Sufficient clearance between the flood defences and the jetty access road and pipe-rack will be incorporated to enable machinery to access the flood defences for inspection/maintenance purposes.</p> <p>Bridleway 36 will be rerouted around the perimeter of Work No. 9, on the North Beck side. The bridleway diversion shall be fenced on both sides to prevent any access to either Work No. 9 or to the North Beck flood defence. The route of the bridleway shall be more than 1m away from the landward toe of the flood defence. Reference is made to a layout drawing given in the response to (Appendix 7) [REP1-025], which includes the indicative route of the bridleway diversion.</p> <p>The Bridleway 36 diversion will include a temporary bridge over the drainage ditch running parallel to the sea wall. The design of this</p>			

Potential Impact	Mitigation/Enhancement Measure	Relevant Work Nos	Responsibility	Enforcing body
	<p>bridge shall be such that flow in the ditch is not restricted and an air gap is always present beneath it. The design of the temporary bridge shall be agreed with the Environment Agency.</p> <p>Water Assets</p> <p>The WMP included within the Final CEMP will include steps to remove the risk of construction works causing damage to water assets including underground water utility pipelines. Project notifications would be communicated to utility service providers, including Anglian Water and others. This service ensures up-to-date information is available on the location of above and below ground cables and pipelines on drawings/maps.</p>			

Table 16: Climate Change

Potential Impact	Mitigation/Enhancement Measure	Relevant Work Nos	Responsibility	Enforcing body
<p>Greenhouse gas emissions.</p> <p>Risks related to severe weather events.</p>	<p>A risk assessment of severe weather impacts on the construction process would be produced by the main contractor to inform the need for construction mitigation measures. Any receptors and/or construction-related operations and activities potentially sensitive to severe weather events will be considered in that assessment. Climate change projections will be considered in the risk assessments.</p>	All Work No's	Contractor	<p>NELC for terrestrial aspects</p> <p>MMO for marine aspects</p>

Potential Impact	Mitigation/Enhancement Measure	Relevant Work Nos	Responsibility	Enforcing body
	<p>The main contractors' Environmental Management System ("EMS") would consider all measures deemed necessary and appropriate to manage severe weather events and would as a minimum cover training of personnel and prevention and monitoring arrangements. These would include (as required):</p> <ul style="list-style-type: none"> a) Use of storm defences (e.g., walls, riprap); b) Designing the Site with refuges and storm-resilient materials and form; and c) Ensuring appropriate storage of plant and materials. <p>As appropriate, construction method statements will also consider severe weather events where risks have been identified. The design of tall structures and jetties will be reviewed to ensure stability of tall structure in stronger wind and wave actions.</p> <p>Risk for crane work will be assessed to make sure the impact of increased wind speeds and gusts are adequately covered.</p> <p>Prevention measures and health and safety plans will be developed to prevent worker exhaustion due to heat, manage flood risk during construction.</p> <p>GHG Assessment</p>			

Potential Impact	Mitigation/Enhancement Measure	Relevant Work Nos	Responsibility	Enforcing body
	<p>Measures would be implemented to reduce embodied carbon in construction materials. Examples include:</p> <ul style="list-style-type: none"> a) Prioritising sourcing secondary/recycled materials, particularly for materials with energy-intensive processing (e.g., green steel) b) Utilising locally-sourced products and those with higher recycled content wherever feasible c) Incorporating recycled content into concrete/replacing cementitious materials with secondary materials (e.g., PFA, GGBS, silica, limestone fines) d) Designing for minimal waste creation e) Reusing site-won materials wherever possible, to minimize the use of natural resources and unnecessary materials (e.g., reclaim waste from enabling works as aggregates/ sub-base) <p>Other measures that would reduce construction-related emissions include:</p> <ul style="list-style-type: none"> a) Switching vehicles and plant off when not in use and ensuring all vehicles conform to current EU emissions standards; b) Pursuing alternatively/renewably powered plant (e.g., biodiesel, hydrogen-powered, battery-powered); and 			

Potential Impact	Mitigation/Enhancement Measure	Relevant Work Nos	Responsibility	Enforcing body
	c) Conducting regular planned maintenance of all operating plant and machinery to optimize efficiency.			

Table 17: Materials and Waste

Potential Impact	Mitigation/Enhancement Measure	Relevant Work Nos	Responsibility	Enforcing body
<p>Reduction in materials required for construction available in the relevant markets.</p> <p>Effects that on-site generated materials have on the existing and future landfill void capacity during Project construction.</p> <p>Changes to allocated/ safeguarded waste site access.</p>	<p>The Project will aim to prioritise waste prevention, followed by preparing for re-use, recycling and recovery and lastly waste disposal to landfill as per the waste hierarchy.</p> <p>A number of designing out waste mitigation measures will be implemented during the Project design and subsequent construction phase and are included in the OSWMP (Appendix A of this Outline CEMP) with the aim of minimising material use, designing for reuse and recovery, future proofing of materials as well as suggested targets for waste recovery and recycled content. A final SWMP will be prepared where appropriate and appended to the relevant final CEMP.</p> <p>The reuse of excavated material would be covered by a CL:AIRE DoW CoP (Ref 4-14) MMP developed by the Contractor before the commencement of construction and for obtaining all necessary approvals (in accordance with the Final CEMP). This would support the re-use of excavated materials; minimise off-site disposal; and demonstrate the necessary lines of evidence to support the proper</p>	All Work No's	Contractor	<p>NELC for terrestrial aspects</p> <p>MMO for marine aspects</p>

Potential Impact	Mitigation/Enhancement Measure	Relevant Work Nos	Responsibility	Enforcing body
	reuse/ offsite disposal of materials and ensure compliance with regulatory guidance.			

Table 18: Ground Conditions and Land Quality

Potential Impact	Mitigation/Enhancement Measure	Relevant Work Nos	Responsibility	Enforcing body
<p>Risks to construction workers</p> <p>[Direct contact with contamination and inhalation of dust/soil derived vapours]</p>	<p>Construction workers on Site will adhere to site-specific health and safety assessments.</p> <p>Site-specific risk assessments and the use of personal protective equipment will form a pre-requisite for workers coming onto Site and would be produced as part of the Construction Phase Plan to be prepared by the Contractor.</p> <p>Entry into excavations or any other enclosed space on a construction site will comply with confined space legislation and be assessed prior to entry.</p> <p>To minimise the risk to off-site human health, general best practice guidance will be followed on Site to minimise dust generation, as outlined in “Environmental Good Practice on Site”, 4th Edition, CIRIA Publication C762 (Ref 4-23) and other relevant guidance and good practice.</p>	<p>Terrestrial aspect of Work No. 1 and Work Nos. 2 – 10 (inclusive)</p>	<p>Contractor</p>	<p>NELC</p> <p>Environment Agency</p>

Potential Impact	Mitigation/Enhancement Measure	Relevant Work Nos	Responsibility	Enforcing body
<p>Degradation of soil resources.</p> <p>Generation of waste soils.</p>	<p>Testing of soils:</p> <p>Potentially contaminated soils will be tested in accordance with BS1997:2004 Eurocode 7, BS16907-1 to 7:2018 Earthworks, BS6031:2009 Code of Practice for earthworks and National Highways (“NH”) guidelines including DMRB Series 600 ‘Earthworks’.</p> <p>Reuse of soils:</p> <p>If it is identified that surplus materials can be reused on Site, the Final Remediation Strategy/Strategies will define any treatment measures required and a risk-based compliance criteria for soils to be screened against prior to reuse.</p> <p>If soil materials are considered to be surplus, the soil materials will be classified under the Waste Framework Directive (“Waste FD”) (2009/98/EC) (Ref 4-15) as hazardous (17-05-03) or non-hazardous (17-05-04) soils using a propriety assessment tool (e.g., “HazWasteOnlineTM”).</p> <p>Waste acceptance criteria (“WAC”) testing will be required if waste is deemed as hazardous before disposal in a landfill.</p>	<p>Terrestrial aspect of Work No. 1 and Work Nos. 2 – 10 (inclusive)</p>	<p>Contractor</p>	<p>NELC</p> <p>Environment Agency</p>
<p>Impact to Soils</p>	<p>Topsoil removal or stockpiling is not proposed in the Laporte Road Temporary Construction Area (Work No. 9) as soils will need to be levelled and compacted, prior to use as a laydown area. This area will be subject to light grading, with a breathable heavy duty ground mat</p>	<p>Work No. 9</p>	<p>Contractor</p>	<p>NELC</p>

Potential Impact	Mitigation/Enhancement Measure	Relevant Work Nos	Responsibility	Enforcing body
	<p>protection applied following these works to reduce potential compaction from materials laydown and associated activities.</p> <p>Following the completion of construction activities, agricultural land taken on a temporary basis will be restored and returned to the landowner for agricultural use.</p>			
Impact to Soils	<p>Potential impacts specific to contamination impacting on soil resources will be mitigated through the following measures:</p> <ul style="list-style-type: none"> a) Works will be in compliance with BS 3882:2015 'British Standard Specification for Topsoil and Requirements for Use' (2015) and the Construction Code of Practice for the sustainable use of soils on construction sites (Ref 4-24). b) The source of topsoil will be investigated carefully with respect to its suitability for the intended use. c) A Soil Management Plan, based on the Outline Soil Management Plan (Appendix B to this Outline CEMP) will be prepared by the contractor prior to the start of construction and will form an appendix to the Final CEMP, where relevant, detailing the areas and type of topsoil/subsoil to be stripped, stripping method, haul routes and the management of the soil stockpiles. d) Topsoil will be handled only in the appropriate conditions of weather and soil moisture, and with suitable machinery. 	<p>Terrestrial aspect of Work No. 1 and Work Nos. 2 – 10 (inclusive)</p>	Contractor	<p>NELC</p> <p>Environment Agency</p>

Potential Impact	Mitigation/Enhancement Measure	Relevant Work Nos	Responsibility	Enforcing body
	<p>e) The stockpiling of soils will be avoided whenever possible. Where stockpiling is unavoidable, heaps would be tipped loosely and the surface firmed and shaped to shed water.</p> <p>f) Where possible, topsoil will be re-used on site as applicable.</p> <p>g) The movement of traffic will be confined to designated haul routes to reduce the amount of heavy machinery going over soil materials which could cause compaction of soil materials. Such routes would exclude areas of proposed landscaping.</p>			
Impacts to surface waters	<p>To minimise the potential for run-off from material stockpiles to surface water bodies, any stockpiled material stored on the Site will be stored at a suitable distance from watercourses. If such material stockpiles are not used within three months, temporary covers or reseeded measures, for soils, will be implemented. Erosion protection matting may also be used. Collectively, these measures will minimise the potential for sediment mobilisation via wind and water flows.</p> <p>To further prevent the potential for surface run-off and mobilisation of potential contaminants, any washing of vehicles and equipment will be undertaken in controlled areas only. Such locations will be agreed with the local planning authority and/or the EA and will be defined in the Final CEMP.</p> <p>Stockpiled materials will be located away from watercourses and will be reseeded or temporarily covered if they are not to be used within 3 months and following the reinstatement of the proposed development.</p>	Terrestrial aspect of Work No. 1 and Work Nos. 2 – 10 (inclusive)	Contractor	NELC Environment Agency

Potential Impact	Mitigation/Enhancement Measure	Relevant Work Nos	Responsibility	Enforcing body
	<p>Erosion protection matting may be used to minimise sediment in water flow or wind.</p> <p>Impermeable surfacing and bunding has been incorporated into the design of the Project, where appropriate, to mitigate potential effects associated with the accidental spillage of polluting materials.</p> <p>Measures will be set out in the Final CEMP and adhered to during construction, in order to prevent or minimise spillage risks and impacts during the construction phase. The measures will also address accidental spillages associated with building construction, foundations, concrete usage and the management of concrete batching.</p> <p>Vehicle and equipment washing will only take place in controlled areas.</p>			
Impacts to groundwater	<p>Piling and deep foundations:</p> <p>Following any further Ground Investigation and geotechnical assessments, the construction methodology of the Project will be assessed prior to commencement of the Project to consider and reduce if necessary the potential risk associated with the development of preferential pathways if piling, other deep foundations or ground improvements are required.</p> <p>Preferential pathways may be created between the Made Ground, superficial Secondary Undifferentiated Aquifers and the Principal</p>	<p>Work No. 3 and Work No. 5</p>	Contractor	<p>NELC</p> <p>Environment Agency</p>

Potential Impact	Mitigation/Enhancement Measure	Relevant Work Nos	Responsibility	Enforcing body
	<p>Aquifer in the bedrock as a result of the construction of the Project. For example, if piled foundations are required and contamination is identified on the Site, it is anticipated that a piling risk assessment will be undertaken which will comply with industry best practice such as the EA Guidance “Piling and Penetrative Ground Improvement Methods on Land Affected by Contamination: Guidance on Pollution Prevention” (Ref 4-17) and “Piling in Layered Ground: risks to groundwater and archaeology – Since Report SC0200074/SR” (Ref 4-18). Piling method statements would detail measures to protect the aquifer if there is potential to cause pollution.</p> <p>Groundwater monitoring:</p> <p>Groundwater monitoring would be undertaken as defined in the Outline Remediation Strategy (Appendix 21.C of the ES [APP-217])</p>			
Impacts from ground gases	<p>Updated Ground Gas Risk Assessment:</p> <p>The Ground Gas Risk Assessment (See Appendix 21.B of the ES [APP-216]) (RB17 methodology), using the average TOC of 1.25% in Made Ground, has classified the Site areas as Characteristic Situation CS2. The Characteristic Situation rating is based on the CL:AIRE RB17 (Ref 4-14) Methodology and is anticipated to represent the worst-case scenario. CS2 is defined as a low risk associated with ground gas.</p>	Work No. 3 and Work No. 5	Contractor	NELC Environment Agency

Potential Impact	Mitigation/Enhancement Measure	Relevant Work Nos	Responsibility	Enforcing body
	<p>Ground gas monitoring:</p> <p>Additional ground gas monitoring would be undertaken for Work No. 3 and Work No. 5, prior to construction, to confirm the gas and flow rate regime across these parts of the site including gas sampling and laboratory analysis to identify the potential source of the gas and validate the results of the monitoring.</p> <p>The additional ground gas monitoring defined above will be used to confirm the existing Ground Gas Risk Assessment.</p> <p>It is anticipated that buildings will be designed for a Characteristic Situation CS2.</p> <p>Design Response:</p> <p>During construction, access to confined spaces and excavations would be restricted. Where work in confined spaces is unavoidable, a site-specific and task specific risk assessment would be undertaken prior to the commencement of the works. This assessment would cover potential risks to both the construction staff and the local population. Monitoring of confined spaces for potential ground gas accumulation would be carried out and the works would be undertaken by suitably trained personnel with the use of specialist personal protective equipment where necessary.</p>			

Potential Impact	Mitigation/Enhancement Measure	Relevant Work Nos	Responsibility	Enforcing body
Impacts to underground assets	Prior to the commencement of any underground works, the Applicant will undertake any required additional utility surveys to identify any underground infrastructure where underground construction works are planned.	All Work No's	Contractor	Utilities companies as relevant
Risks associated with coal mining hazards	The Project lies within a coal mining area which may contain unrecorded coal mining related hazards. If any coal mining feature is encountered during development, this would be reported immediately to the Coal Authority on 0345 762 6848.	All Work No's	Contractor	Coal Authority

Table 19: Major Accidents and Disasters

Potential Impact	Mitigation/Enhancement Measure	Relevant Work Nos	Responsibility	Enforcing body
<p>Potentially harmful substances causing injury or entering the environment e.g. into watercourses.</p> <p>Use of diesel: release which is ignited could cause harm to people via exposure to thermal radiation in a fire, or if unignited, diesel can cause harm to people if</p>	<p>Measures to prevent spillages to watercourses are covered in Table 3.13.</p> <p>The Construction, Design and Management Regulations (“CDM”) regulations (Ref 4-25) will be followed as required throughout the design phase which includes the development of design Risk Register(s). These are live documents, maintained by the Project Manager throughout the design and construction phases of projects to identify and document risks, assign ownership, priority and mitigation measures.</p> <p>Standard Mitigation Measures</p>	All Work No's	Contractor	NELC and HSE/EA (pursuant to the COMAH Regulations)

Potential Impact	Mitigation/Enhancement Measure	Relevant Work Nos	Responsibility	Enforcing body
<p>inhaled, ingested or exposed to skin. A release of diesel to the environment such as the Humber could result in harm to flora and fauna.</p> <p>Construction work can include potentially hazardous activities such as working near to overhead power supplies or buried services such as power cables and gas transmission mains.</p> <p>Electrical systems strike leading to harm to people including fatal injuries.</p> <p>Underground gas main/unexploded ordnance ("UXO") strike leading to release of gas and fire/explosion with harm</p>	<p>Formal risk assessments to identify potential hazards during construction (HAZCON) are typically carried out prior to completion of the design phase for process facilities such as the Project to ensure compliance with the COMAH Regulations. This will involve development of the pre-construction information package to be included in the tender documents for review by the Principal Contractor. Once appointed, the Principal Contractor will develop a Construction Phase Plan in compliance with CDM Regulations. It is anticipated that the construction of this facility will be a HSE notifiable project.</p> <p>During construction, a formal risk assessment of the potential hazards of simultaneous operations ("SIMOPS") will be carried out where activities at the Project are in close proximity to existing operational facilities and there is a potential for conflict. This risk assessment will involve representatives from the Project alongside stakeholders such as neighbouring facilities, electricity and gas transmission specialists where there are existing high voltage electrical systems and gas pipelines and others as appropriate.</p> <p>Established protocols will be used to develop Safety Systems of Work ("SSoW") for activities carried out in the vicinity of high pressure ("HP") gas transmission pipelines and high voltage ("HV") electricity transmission systems. These protocols include guidance documents published by the HSE, National Grid and other network operators:</p>			

Potential Impact	Mitigation/Enhancement Measure	Relevant Work Nos	Responsibility	Enforcing body
<p>to people including potential for fatal injuries.</p> <p>Incident during construction</p>	<p>a) HP gas pipelines can operate at pressures up to 90 bar and are normally buried to a depth of at least 1.1 m. An excavation of 0.3 m or more above the pipeline must have prior agreement with the pipeline operator whose representative will typically be on site while the work is in progress to provide information and supervise activities.</p> <p>b) HV electrical cables operate at voltages up to 400kV and can either be connected to overhead transmission systems or buried below ground level. There are defined clearance distances to be observed between these cables and any structure or work activity.</p> <p>Contact with high voltage electricity</p> <p>Project notifications would be communicated to utility service providers, including National Grid and others. This service ensures up-to-date information is available on the location of above and below ground electrical cables on drawings/maps.</p> <p>Locations of utilities will be confirmed by use of specialist tools to detect underground cables and pipes.</p> <p>During the construction phase of the Project, activities which would be carried out in proximity to HV electrical distribution networks would be carefully controlled via risk assessments.</p>			

Potential Impact	Mitigation/Enhancement Measure	Relevant Work Nos	Responsibility	Enforcing body
	<p>Appropriate techniques including hand-dig would be used as required by these risk assessments.</p> <p>Protective measures and safety signage would be used to alert personnel to overhead and below ground electrical hazards.</p> <p>Only suitably qualified and experienced personnel (“SQEP”) would operate equipment such as cranes and excavators.</p> <p>Contact with underground gas main or UXO</p> <p>Measures as Risk Event 1 for underground services such as gas mains.</p> <p>The Project would work with UK Gas Transmission services to ensure work is carried out safely where gas infrastructure has been identified as present.</p> <p>An UXO survey would be completed for the Site and any remedial activities safely completed prior to construction commencing.</p> <p>Construction incident – structural collapse, collision</p> <p>The engineering design of the Project, in particular civil and structural engineering would be carried out in accordance with all applicable legislative requirements and industry standards.</p>			

Potential Impact	Mitigation/Enhancement Measure	Relevant Work Nos	Responsibility	Enforcing body
	<p>Groundworks to ensure site stability would be carried out as part of the Project development.</p> <p>Equipment and vehicles used during construction would be carefully selected and appropriate temporary construction access installed.</p> <p>Security controls would be in place throughout construction including guards and CCTV to prevent unauthorized access to Site.</p>			

Table 20: Socio-Economics

Potential Impact	Mitigation/Enhancement Measure	Relevant Work Nos	Responsibility	Enforcing body
<p>Potential effects on PRow includes impacts on users of footpaths, bridleways, byways and National Cycle Network (“NCN”) routes from disruption to or diversion of journeys.</p> <p>Potential impacts to residents of Kings</p>	<p>As a result of the diversion of Public Bridleway 36 during the construction phase, adequate signage will be put into place.</p> <p>During construction, residents along Kings Road would be notified via a letter drop of the timings, duration and details of any works to utilities along Kings Road.</p>	Work No’s 2,9 and 10	Contractor	NELC

Potential Impact	Mitigation/Enhancement Measure	Relevant Work Nos	Responsibility	Enforcing body
Road during construction				

3.2 Implementation and Operation

3.2.1 The Final CEMP will set out all roles, responsibilities and actions required in respect of implementation of the measures described in this Outline CEMP, including:

- a. An organogram showing team roles, names and responsibilities.
- b. Training requirements for relevant personnel on environmental topics.
- c. Information on site briefings and toolbox talks that will be used to equip relevant staff with the necessary level of knowledge to follow environmental control procedures.
- d. Measures to advise employees of changing circumstances as work progresses.
- e. Communication methods.
- f. Document control.
- g. Environmental emergency procedures.

Monitoring

- 4.1.1 To meet the requirement of the Final CEMP, environmental monitoring of the Project and its impacts will be undertaken throughout the construction phase. In particular, the following requirements of the Final CEMP will be closely monitored:
- a. Licences, permits and approvals
 - b. Dust and noise monitoring
 - c. Water pollution prevention
 - d. Vegetation protection
- 4.1.2 Specific monitoring requirements outlined within the topic specific tables within **Section 0** above are presented in **Table 21** below:

Table 21: Monitoring Requirements

ES Chapter	Monitoring Requirements
<p>Chapter 6: Air Quality</p>	<p>Record of meteorological conditions to be kept each day to include:</p> <ul style="list-style-type: none"> • Date; • Description of conditions in AM and PM (sunny, dry, cloudy, wet, windy, etc); • Predominant wind direction in AM and PM; • Wind speed in AM and PM. <p>Undertake daily on-site and off-site inspection, where receptors (including roads) are nearby, to monitor dust, record inspection results, and make the log available to the local authority when asked. This will include regular dust soiling checks of surfaces such as street furniture, cars and window sills within 100 m of the Site Boundary, with cleaning to be provided if necessary. This would include the following information:</p> <ul style="list-style-type: none"> • Date and time • Summary of meteorological conditions • Whether or not evidence of dust deposition is found • If so, where and to what extent • A summary of the operational activities undertaken that day

ES Chapter	Monitoring Requirements
	<ul style="list-style-type: none"> • A description of the remedial actions taken and changes made to operational procedures, in order to eliminate or minimise dust emissions • Details of any complaints received. <p>Carry out regular site inspections to monitor compliance with the DMP, record inspection results, and make an inspection log available to the local authority when asked.</p> <p>Increase the frequency of site inspections by the person accountable for air quality and dust issues on site when activities with a high potential to produce dust are being carried out and during prolonged dry or windy conditions.</p> <p>Agree dust deposition, dust flux, or real-time PM₁₀ continuous monitoring locations with the Local Authority. Where possible commence baseline monitoring at least three months before work commences on site or, if it is a large site, before work on a phase commences.</p> <p>It is not anticipated that quantitative monitoring will be required during the works. However, should the regular visual inspections identify that significant quantities of dust have traversed the Site Boundary, and or if there are regular substantiated complaints, then quantitative monitoring will be required.</p>
Chapter 7: Noise and Vibration	Monitoring of noise and vibration complaints and reporting to the contractor for immediate investigation.
Chapter 8: Nature Conservation (Terrestrial Ecology)	<p>An ECoW will be present during construction as appropriate to oversee implementation of impact avoidance commitments.</p> <p>A Water Vole Class Licensed Ecologist will be appointed to oversee the works to Ditch 5 that will be undertaken under a Natural England Water Vole Class Licence.</p>
Chapter 11: Traffic and Transportation	Travel Plan Co-ordinator to oversee monitoring of the individual measures within the CTMP and CWTP.
Chapter 12: Marine Transport and Navigation	<p>Weather forecasting and monitoring shall be carried out and compared with the allowable weather limits for reliable planning and assessment of risk regarding the weather operating limits.</p> <p>A maximum speed limit of 5 knots will apply to vessels passing the Project Berth (similar to IOT). VTS will monitor for unsafe speeds, including during construction work.</p>

ES Chapter	Monitoring Requirements
	<p>Load monitoring. Monitoring will be in place to detect any ranging of a berthed vessel prior to a potential breakout.</p> <p>CCTV will be used to monitor the jetty area.</p>
Chapter 15: Historic Environment (Marine)	Monitoring of AEZs
Chapter 18: Water Quality, Coastal Protection, Flood Risk and Drainage	<p>It will be for the Contractor to continually monitor fine sediment and water runoff and the need for measures depending on the nature of the works being undertaken the weather conditions, and the performance of sustainable drainage systems installed.</p> <p>During the construction phase, the Contractor would monitor weather forecasts on a monthly, weekly and daily basis, and plan works accordingly.</p>

4.1.3 As part of the monitoring process the contractor will allocate a designated Environmental Site Officer(s), who will be present on Site throughout the construction process and when new activities are commencing. The Environmental Site Officer will observe site activities and report any deviations from the Final CEMP in a logbook, along with the action taken and general conditions at the time. The Applicant will be informed of any deviations from the Final CEMP as soon as possible following identification of such issues. The Environmental Site Officer would also act as day-to-day contact with the relevant stakeholders.

4.1.4 During construction, the Environmental Site Officer will conduct daily walkover surveys to ensure all requirements of the Final CEMP are being met. Action from these surveys will be documented on an Environmental Action Schedule, discussed with the Site Foreman for programming requirements and issued weekly for actioning.

4.1.5 The Environmental Manager/ Project Manager will arrange regular formal inspections to ensure the requirements of the Final CEMP are being met. After completion of the works, the Environmental Site Officer will conduct a final review.

4.2 Records

4.2.1 The Environmental Manager/Project Manager together with the EcoW will retain records of environmental monitoring and implementation of the Final CEMP. This will allow provision of evidence that the Final CEMP is being implemented effectively. These records will include:

- a. Environmental Action Schedule

- b. Licences, permits and approvals
 - c. Results of inspections by Environmental Manager/Project Manager
 - d. Other environmental surveys and investigations
 - e. Environmental equipment test records
- 4.2.2 The Final CEMP will be updated as necessary, with a full review as required (at least quarterly) throughout the construction period.

References

- Ref 4-1 Construction Industry Research and Information Association (CIRIA) (2015). Environmental Good Practice on Site, 4th Edition, CIRIA Publication C741.
- Ref 4-2 Defra (2009). Defra Construction Code of Practice for the Sustainable Use of Soil on Development Sites. Accessed February 2023.
- Ref 4-3 Holman et al. (2014), Guidance on the assessment of dust from demolition and construction. Version 1.
- Ref 4-4 British Standards Institute (BSI). (2014). BS 5228:2009+A1:2014: Code of practice for noise and vibration control on construction and open site– Part 1: Noise’.
- Ref 4-5 British Standards Institute (BSI). (2014). BS 5228:2009+A1:2014: Code of practice for noise and vibration control on construction and open site – Part 2: Vibration’.
- Ref 4-6 JNCC (2010). Statutory nature conservation agency protocol for minimising the risk of injury to marine mammals from piling noise.
- Ref 4-7 The Stationery Office (1981). Wildlife and Countryside Act 1981.
- Ref 4-8 The British Standard (2012). Trees in Relation to Design, Demolition and Construction to Construction - Recommendations (BS 5837).
- Ref 4-9 JNAPC (2006). JNAPC Code of Practice for Seabed Development. York, Joint Nautical Archaeology Policy Committee.
- Ref 4-10 Historic England (2016) The Assessment and Management of Marine Archaeology in Port and Harbour Development. Swindon, Historic England
- Ref 4-11 The Stationary Office Limited (1991). Water Resources Act 1991.
- Ref 4-12 HM Government (2014). The Water Act 2014.
- Ref 4-13 Environment Agency (2022). Catchment Data Explorer.
- Ref 4-14 Contaminated Land: Applications in Real Environments (CL:AIRE), (2011), Definition of Waste: Development Industry Code of Practice (DoWCoP), Version 2.
- Ref 4-15 European Parliament and Council. (2008). Directive 2008/98/EC Waste Framework Directive.
- Ref 4-16 British Standard, BS 3882:2015, Specification for Topsoil and Requirements for Use’ (2015) and the Construction Code of Practice for the sustainable use of soils on construction sites. Contaminated Land: Applications in Real

Environments. The Definition of Waste: Development Industry Code of Practice, March 2011.

- Ref 4-17 Westcott, F.J., Lean, C.M.B. and Cunningham. (2001). M.L. Piling and Penetrative Ground Improvement Methods on Land Affected by Contamination: Guidance on Pollution Prevention. Bristol : Environment Agency.
- Ref 4-18 Hird, C.C, Emmett, K.B. and Davies, G. Piling. (2006). Layered Ground: risks to groundwater and archaeology – Science Report SC0200074/SR. Bristol: Environment Agency.
- Ref 4-19 British Standards Institute. (2004). BS EN 1997:2004+A1:2013. Eurocode 7. Geotechnical design – General rules.
- Ref 4-20 British Standards Institute. (2018) BS16907-1 to 7:2018 Earthworks
- Ref 4-21 British Standards Institute. (2009). BS1997:2004 Eurocode 7, BS6031:2009 Code of Practice for earthworks
- Ref 4-22 Highways England. (2016). Manual of Contract Documents for Highway Works Volume 1 Specification for Highway Works. Series 600 Earthworks. Amendment February 2016
- Ref 4-23 Law (eds), Charlie and D'Aleo (eds), Sirio. (2016). CIRIA C762 Environmental Good Practice on Site Pocket Book (Fourth Edition). London : CIRIA.
- Ref 4-24 British Standard, BS 3882:2015, Specification for Topsoil and Requirements for Use' (2015) and the Construction Code of Practice for the sustainable use of soils on construction sites.
- Ref 4-25 HMSO (2015). The Construction (Design and Management) Regulations 2015.
- Ref 4-26 National Joint Utilities Group (NJUG) (2007). Vol 4 Issue 2 – Guidelines for the Planning, Installation and Maintenance of Utility Apparatus in Proximity to Trees.

Appendix A: Outline Site Waste Management Plan



Immingham Green Energy Terminal

TR030008

Volume 6

Appendix A – Outline Site Waste Management Plan

Planning Act 2008

Regulation 5(2)(a)

Infrastructure Planning (Applications: Prescribed
Forms and Procedure) Regulations 2009 (as
amended)

September 2023

Infrastructure Planning

Planning Act 2008

The Infrastructure Planning
(Applications: Prescribed Forms and
Procedure) Regulations 2009 (as amended)

Immingham Green Energy Terminal

Development Consent Order 2023

Appendix A – Outline Site Waste Management Plan

Regulation Reference	APFP Regulation 5(2)(a)
Planning Inspectorate Case Reference	TR030008
Application Document Reference	TR030008/APP/6.5
Author	Associated British Ports Air Products BR

Version	Date	Status of Version
Revision 1	21 September 2023	DCO Application

Table of contents

Chapter	Pages
1. Introduction	1
1.2. Requirements of a SWMP	2
2. Waste Management Legislation	3
2.2. Definition of Waste	3
2.3. Duty of Care	3
2.4. Apply the Waste Hierarchy	3
2.5. Registration of Waste Carriers	4
2.6. Environmental Permits and Exemptions	4
3. Details of the Project.....	6
3.2. Description of the Project	7
4. Estimate of Material Use and Waste Arisings.....	8
4.1. Introduction	8
4.2. Waste	8
5. Design decisions.....	12
6. Management Arrangements	14
6.1. Roles and responsibilities.....	14
6.2. Key Performance Indicators	15
7. Materials and Waste Management On-Site	16
7.2. Waste hierarchy	16
7.3. Waste management routes	17
7.4. Site waste management measures	18
7.5. Waste Carriers and Facilities	24
7.6. Waste Documentation	24
7.7. Fly-tipping.....	26
7.8. Reporting and Auditing.....	26
7.9. Review of SWMP	27
7.10. Additional Duty of Care Checks	27
7.11. Site Inspections	27
7.12. Closure Reporting	27
8. References.....	28
9. Glossary and Abbreviations.....	29
Annex A – Waste carriers.....	31
Annex B – Construction Materials Imported to Site	32
Annex C – Waste Management.....	33
 Tables	
Table 1: Project Details.....	6
Table 2: Total Construction Phase Waste.....	9
Table 3: Standard, Good and Best Practice Recovery Rates by Material.....	11

Table 4: Waste Prevention Opportunities and Decisions	13
Table 5: Responsibilities for producing the SWMP	14
Plate 1: The Waste Hierarchy, from Defra's Guidance on Applying the Waste Hierarchy .	16
Table 6: On-site Waste Management Measures to Adhere to the Waste Hierarchy	18
Table 7: Best Practice On-site	21

Plates

Plate 1: The Waste Hierarchy, from Defra's Guidance on Applying the Waste Hierarchy .	16
---	----

1. Introduction

- 1.1.1. This Outline Site Waste Management Plan (OSWMP, hereafter referred to as the “Plan”) has been prepared by AECOM Ltd (“AECOM”) on behalf of Associated British Ports (“ABP”) (“The Applicant”). It supports an application for development consent (“the Application”) for the construction, operation and maintenance of a multi-user bulk liquid Terminal, which would be located on the eastern side of the Port of Immingham (hereafter “the Port”), as well as associated development (collectively termed “the Project”). A part of the Associated Development is the construction and operation of a green hydrogen production facility for the production of green hydrogen from imported ammonia on-site by Air Products BR Ltd. (“Air Products”).
- 1.1.2. This document forms part of the Outline Construction Environmental Management Plan (“Outline CEMP”) [TR030008/APP/6.5]. The landside elements of the Project are located within the administrative boundary of North East Lincolnshire Council (“NELC”).
- 1.1.3. The principal aim of this Plan is outline sustainable methods for managing onshore construction, demolition and excavation (“CD&E”) waste to be adopted during the CD&E phases of the Project. Dredged materials are not covered by this Plan. It is expected that the dredged materials would be disposed of at licenced sites within the estuary and are not anticipated to be brought onshore (unless material is not suitable for management in the estuary e.g. contaminated material). Furthermore, with regards to managing CD&E waste associated with the Project, this Plan has the following aims:
- a. To contribute towards achieving emerging, current and long term, Project, national (England) and Local (NELC) targets for waste minimisation, recycling and reuse of CD&E waste arisings.
 - b. To provide a summary of the CD&E works to provide context for the anticipated waste arisings and management.
 - c. To facilitate the contractor to comply with all applicable legal requirements for handling CD&E waste.
 - d. To facilitate the contractor to achieve high standards of waste management performance.
- 1.1.4. The Plan provides a review of the requirements placed upon the Project under waste management legislation and policy at all levels of government (i.e. national (England) and Local (NELC)).
- 1.1.5. For the purpose of this Plan, waste is defined as per the Waste Framework Directive (Waste FD) (2008/98/EC) as “any substance or object which the holder discards or intends or is required to discard” (Ref 1-1).

1.1.6. This Plan forms part of the Outline CEMP [TR030008/APP/6.5] which has been prepared and accompanies the Application. The development of a CEMP by the contractor is secured by a requirement of the draft Development Consent Order (“DCO”). Once appointed, the contractor shall use this Plan to develop a Site Waste Management Plan (“SWMP”) as part of any Final CEMP and thereafter manage waste generated by the Project in accordance with that SWMP.

1.2. Requirements of a SWMP

1.2.1. Whilst The Site Waste Management Plans Regulations 2008 (Ref 1-2) were repealed in December 2013 (Ref 1-3), the production of a SWMP for developments is regarded as best practice.

1.2.2. This Plan has been developed to act as a guide to those involved in the construction of the Project on how to manage resources and waste, in accordance with best practice requirements. The contractor shall use this Plan as a framework for producing their own SWMP for use throughout the duration of construction.

2. Waste Management Legislation

2.1.1. This section summarises the key legal requirements with regards to waste management and control within England.

2.2. Definition of Waste

2.2.1. Waste is defined by Article 1(a) of the Waste FD (Ref 1-1) as “any substance or object (in the categories set out in Annex I) which the holder discards or intends or is required to discard”.

2.2.2. The legal definition of waste also covers substances or objects, which fall outside of the commercial cycle or out of the chain of utility. Most items that are sold or taken off-site for recycling are waste, as they require treatment before they can be resold or reused.

2.2.3. In practical terms, waste can include surplus earthworks materials and soil, scrap, unwanted surplus materials, packaging, recovered spills, office waste, and damaged, worn-out, contaminated or otherwise spoiled plant, equipment and materials.

2.3. Duty of Care

2.3.1. The duty of care for waste management is set out under Section 34 of the Environmental Protection Act 1990 (Ref 1-4) and the Waste (England and Wales) Regulations 2011 (SI 2011 No. 988) (as amended) (Ref 1-5). It requires anyone who produces, imports, keeps, stores, transports, treats or disposes of waste to take all reasonable steps to ensure that the waste is managed properly. Anyone in possession of waste must take all reasonable steps to:

- a. Prevent unauthorised or harmful deposit, treatment or disposal of waste.
- b. Prevent a breach (failure) by any other person to meet the requirement to have an environmental permit, or a breach of a permit condition.
- c. Prevent the escape of waste.
- d. Ensure that waste is transferred to an authorised person; and
- e. Provide an accurate description of the waste when it is transferred to another person, by using a compulsory system of Waste Transfer Notes (“WTNs”) that control the transfer of waste between parties.

2.3.2. The Waste Duty of Care Code of Practice (Ref 1-6) sets out practical guidance on how to meet waste duty of care requirements. Failure to comply with the duty of care requirements is a criminal offence and could lead to prosecution.

2.4. Apply the Waste Hierarchy

2.4.1. The Waste (England and Wales) Regulations 2011 (as amended) (Ref 1-5) transpose the requirements of the Waste FD (Ref 1-1), and require:

- a. Those undertaking waste management activities, such as the import, production, collection, transportation, recovery and/or disposal of waste, to

take all reasonable measures to apply the waste hierarchy, in priority order, as follows:

- i. Prevention.
 - ii. Preparation for reuse.
 - iii. Recycling.
 - iv. Other recovery, such as energy recovery.
 - v. Disposal.
- b. Those producing waste to confirm that they have applied the waste hierarchy when transferring waste and to include a declaration on their WTN or Hazardous Waste Consignment Note (“HWCN”).

2.5. Registration of Waste Carriers

- 2.5.1. Under the Control of Pollution (Amendment) Act 1989 (Ref 1-7) it is a criminal offence for anyone not registered as a waste carrier to transport controlled waste. The Waste (England and Wales) Regulations 2011 (as amended) (Ref 1-5) updated the system for the registration of waste carriers, including brokers and dealers.
- 2.5.2. Anyone undertaking any of the following activities as part of their business must register as a waste carrier, broker or dealer:
- a. Transporting their own waste.
 - b. Transporting waste for someone else.
 - c. Buying or selling waste.
 - d. Acting as a waste broker (arranging for someone to handle waste produced by someone else).
- 2.5.3. Details of all appointed waste carriers, brokers and contractors shall be included in the Principal Contactor’s SWMP, including copies of appropriate waste carrier licences/registrations. The register of waste carriers, brokers and dealers can be checked using the Environment Agency’s Public Registers.

2.6. Environmental Permits and Exemptions

- 2.6.1. The Environmental Permitting (England and Wales) Regulations 2016 (as amended) (Ref 1-8) require sites where waste is processed, treated or disposed of to hold a valid environmental permit issued by the Environment Agency. The Regulations also include a schedule of activities that are exempt from the requirements of permitting. However, to comply with the Regulations, an exempt activity must generally be registered with the Environment Agency before commencing.
- 2.6.2. A permit is not usually required where waste is temporarily stored on the site where it is produced prior to management or disposal. Depending upon the types and quantities of waste to be stored, the duration and place of storage and compliance with other defined conditions:

- a. A Non-Waste FD exemption may apply, which does not need to be registered.
 - b. An exemption may need to be registered with the Environment Agency.
- 2.6.3. Information on the limits and conditions for storing waste exemptions and Non-Waste FD exemptions are available online from the Government website (Ref 1-17).
- 2.6.4. The contractor shall be responsible for obtaining the necessary permits and exemptions, where required.

3. Details of the Project

3.1.1. The contractor shall complete **Table 1** prior to commencement of construction of the Project.

Table 1: Project Details

Project title	Immingham Green Energy Terminal					
Project Location						
Client						
					Email	
					Mobile	
Contractor						
					Email	
					Mobile	
SWMP Drafter						
					Email	
					Fax	
Construction cost (estimated)						
Site area (gross area)						
Construction programme:						
Start date	Day		Month		Year	
Completion date					Year	
Waste Management Champion						
Person responsible for SWMP						
Document Controller / Secretary						

Project title	Immingham Green Energy Terminal
Location of SWMP	

3.2. Description of the Project

- 3.2.1. The details of the Project are outlined in **Chapter 2: The Project [TR30008/APP/6.2]** of the Environmental Statement.

4. Estimate of Material Use and Waste Arisings

4.1. Introduction

4.1.1. This Plan provides estimates of the types and quantities of waste arising during construction of the Project and the likely management route and potential recovery rates.

4.1.2. The contractor shall review, update and monitor these estimates throughout the design and construction of the Project, and incorporate these updates in the SWMP to ensure delivery of the Project Key Performance Indicators (“KPIs”).

4.2. Waste

4.2.1. The main types and quantities of waste expected to arise during all phases have been estimated. Full details of how waste has been estimated is outlined in **Chapter 20: Materials and Waste [TR30008/APP/6.2]**. Total construction phase waste is outlined in **Table 2** below.

Table 2: Total Construction Phase Waste

	Waste (m ³)	Waste Types	Waste Management Routes
Construction waste Phase 1, Phase 2, subsequent Phases (3-6) and jetty (based on construction value)	73,700	<p>Wastage from construction materials e.g. concrete, steel, asphalt, aggregates, plastic.</p> <p>Packaging from materials delivered to site e.g. timber crates.</p> <p>Construction worker wastes from offices and welfare areas/canteens.</p> <p>Waste oils from construction plant.</p>	Recycling and recovery
Demolition and clearance waste Phase 1 and Jetty	Small quantities	<p>Waste arisings from demolition and clearance. Extensive demolition is not anticipated as the Site is either hardstanding, brownfield or agricultural field.</p> <p>Vegetation from site clearance.</p>	Recycling and recovery
Excavated material Phase 1	22,336	<p>Surplus excavated materials.</p> <p>Surplus topsoil and subsoil.</p> <p>Unsuitable and contaminated soils and excavated materials.</p>	Recycling, recovery and disposal
Excavated material Jetty (300m deep strip across the roadway and ramp area as part of the vegetation clearance)	2,019	<p>Surplus excavated materials.</p> <p>Surplus topsoil and subsoil.</p> <p>Unsuitable and contaminated soils and excavated materials.</p>	Recycling, recovery and disposal

Immingham Green Energy Terminal
 Outline Construction Environmental Management Plan – Appendix A – Outline Site Waste Management Plan

	Waste (m ³)	Waste Types	Waste Management Routes
Waste aggregates - at the end of construction from jetty temporary crane platform and vehicle turning area and temporary vehicle access route	2,675	Aggregate	Recycling and recovery

4.2.2. Standard, good and best practice recovery rates by material are provided by the Waste & Resources Action Programme (“WRAP”) (Ref 1-9). Recovery rates for key construction materials and other construction wastes relevant to the Project’s construction phase are provided in **Table 3** below.

Table 3: Standard, Good and Best Practice Recovery Rates by Material

Material	Standard practice recovery (%)	Good practice quick win (%)	Best practice recovery (%)
Timber	57	90	95
Metals	95	100	100
Plasterboard (excludes demolition)	30	90	95
Packaging	60	85	95
Ceramics/masonry	75	85	100
Concrete	75	95	100
Inert	75	95	100
Plastics	60	80	95
Miscellaneous	12	50	75
Electrical equipment	Limited information	70*	95
Furniture	0-15	25	50
Insulation	12	50	75
Cement	Limited information	75	95
Liquids and oils	100	100	100
Hazardous	50	Limited information, this cannot be 100% as much hazardous waste (e.g., asbestos) must be landfilled.	

* This is a required recovery target for the type of Waste Electrical and Electronic Equipment (“WEEE”) likely to be produced from construction sites, e.g., lighting (WEEE Regulations, 2013) (Ref 1-10).

(Based on the WRAP (13.1.1a.ii.Ref 1-9))

5. Design decisions

- 5.1.1. Decisions made during the design stages (pre-application and post consent) of the Project can impact on the quantity and types of materials used, waste arising, and the management of waste.
- 5.1.2. This section describes the design decisions made to date, sets out the design considerations for detailed design and provides a table (**Table 4**) which will be completed by the contractor to document further opportunities for waste prevention and decisions taken regarding material resource use and waste management.
- 5.1.3. The following good practice measures would be implemented during the design and construction phases of the Project, where practicable:
 - a. Manage waste in accordance with the waste hierarchy.
 - b. Design-out and prevent waste arising.
 - c. Reuse excavated earthworks materials within the project.
 - d. Recycle demolition materials arising from the project within the construction of the project.
 - e. Divert waste from landfill through off-site recycling and recovery.
 - f. Use recycled and secondary materials in the construction of the project.
- 5.1.4. The following designing out waste mitigation measures will be implemented during the Project design and subsequent construction phase:
 - a. Design for reuse and recovery: identifying, securing and using materials that already exist on site, or can be sourced from other projects.
 - b. Design for materials optimisation: simplifying the Project layout and form to minimise material use, using standard design parameters, balancing cut and fill, maximising the use of renewable materials and materials with recycled content.
 - c. Design for off-site construction: maximising the use of pre-fabricated structures and components, encouraging a process of assembly rather than construction.
 - d. Design for the future (deconstruction and flexibility): identify how materials can be designed to be more easily adapted over an asset lifetime and how de-constructability and de-mountability of elements can be maximised at end of first life.
 - e. Design for materials and waste efficient procurement: identify and specify materials that can be acquired responsibly, in accordance with a recognised industry standard.
- 5.1.5. At all stages of design and construction, the contractor shall record the following in the SWMP (**Table 4**):
 - a. All opportunities for waste prevention.
 - b. Decisions taken regarding material resource use and waste management.

Table 4: Waste Prevention Opportunities and Decisions

Material/Waste	Estimated Reduction in Waste Arising		Approach by Which Reduction Achieved	Are Any Additional Consents/Permits /Licences Required for the Change?	Estimate Cost Saving	Persons Responsible for Completing Action
	m ³	tonnes				

6. Management Arrangements

6.1. Roles and responsibilities

6.1.1. The main contract personnel responsible for producing the SWMP are shown in **Table 5**.

Table 5: Responsibilities for producing the SWMP

Position	Name	Contact details	SWMP responsibility
Main Contract personnel			
The Client Project Manager			a. Monitors the contractor's performance against the contract, including any environmental commitments and targets agreed for the Project.
Project Manager (Contractor)			a. Approves the SWMP for the relevant phase of works. b. Ensures that all controls specified within the SWMP are implemented by employees and sub-contractors.
Environment Manager /Environmental Clerk of Works (Contractor)			a. Undertakes site inspections to monitor compliance with the environmental licences/consents for the works and the measures within the SWMP. b. Ensures that the Project complies with all environmental legislation, consents, objectives, targets and other environmental commitments.
Site Materials and Waste Manager (Contractor)			a. Prepares the SWMP. b. Implements the SWMP throughout the construction of the Project and ensures that waste is disposed of legally, economically and safely in line with the SWMP and all relevant legislation. c. Provides appropriate professional and practical advice to contractor, consultants and project team

Position	Name	Contact details	SWMP responsibility
			members associated with materials and waste issues.
Sub-contractor details			
Individual Sub-contractor(s), as appointed			<ul style="list-style-type: none"> a. Reads through, familiarises and understands the requirements of the SWMP. b. Produces waste documentation and complies with the requirements set out in the SWMP.

6.2. Key Performance Indicators

- 6.2.1. The national target for recovery of C&D waste is 70% by weight, as set out in the Waste FD (Ref 1-1) and the Waste Management Plan for England (Ref 1-11). The target specifically excludes naturally occurring materials with European Waste Catalogue (“EWC”) Code 17 05 04 (soil and stones other than those mentioned in 17 05 03* (soils and stones containing dangerous substances)). Recovery is deemed to include reuse, recycling and other recovery e.g. energy recovery.
- 6.2.2. A good practice landfill diversion target of 90% has been achieved and exceeded by major UK developments as outlined in the Institute of Environmental Management and Assessment (“IEMA”) Guidance (Ref 1-12). In 2018, the UK generated 67.8 million tonnes of non-hazardous C&D waste, of which 62.6 million tonnes was recovered. This represents a recovery rate of 92.3% (Ref 1-12)
- 6.2.3. Targets for waste recovery and recycled content will be included in the Principal contractor’s SWMP and could include, for example:
- a. Achieving a set percentage (by weight) for recovery of non-hazardous C&D waste. Such a target would specifically exclude naturally occurring materials with EWC Code 17 05 04 (soil and stones other than those mentioned in 17 05 03* (soils and stones containing dangerous substances)). Recovery is deemed to include reuse, recycling and other recovery e.g. energy recovery.
 - b. Achieving a set percentage (by weight) of materials imported to site for use within the Project containing alternative (reused, recycled or secondary) content, for those applications where it is technically and economically feasible to substitute these alternatives to primary materials.

7. Materials and Waste Management On-Site

7.1.1. This section of the Plan details the likely waste management measures and procedures to be implemented on-site during the CD&E phases. Detailed information will be provided in the SWMP prepared by the contractor, once details and methods associated with the CD&E activities are known.

7.1.2. All waste management methods to be implemented on-site shall be in accordance with the waste hierarchy, discussed below.

7.2. Waste hierarchy

7.2.1. Those generating waste have a legal duty of care to comply with the waste hierarchy. The waste hierarchy is a concept that encourages the management and reduction of waste material. The aim is to recover the maximum value from projects/developments by reducing financial losses through material loss during the CD&E phases.

7.2.2. The waste hierarchy is a complex process influenced by the optimal management of any given product/waste material. A basic representation of the waste hierarchy is provided in **Plate 1** and the contractor shall use the hierarchy as a guide to encourage the prevention of waste, followed by reuse and recycling.

Plate 1: The Waste Hierarchy, from Defra's Guidance on Applying the Waste Hierarchy

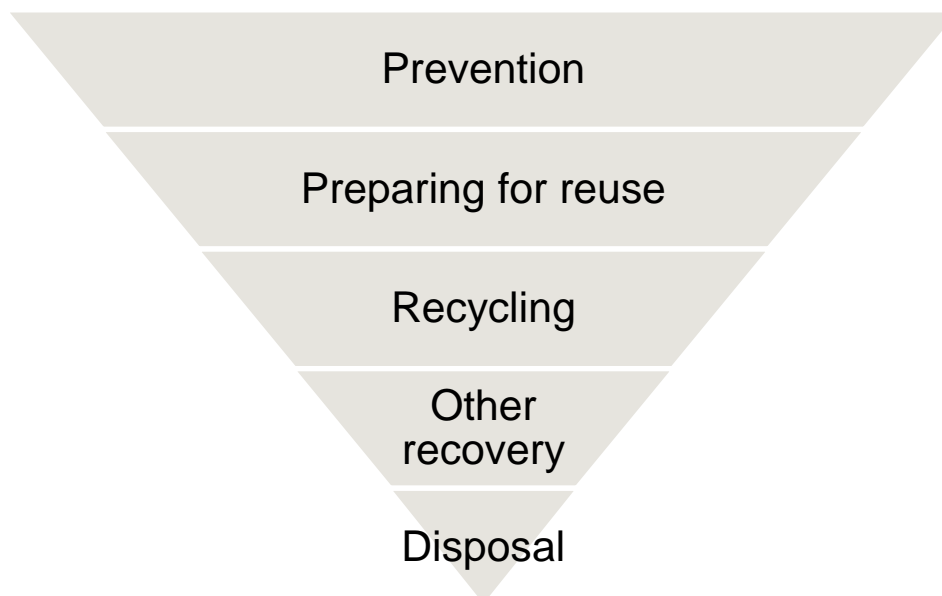

- 7.2.3. When considering waste management options for the Project, the contractor shall take account of the site's location, natural environment and available infrastructure. The contractor shall consider the options in **Section 7.3** when determining the preferred waste management option for each waste stream.

7.3. Waste management routes

Preparing for reuse

- 7.3.1. The aim is to provide design features on the Project to use site-won materials in their current state and form. Reuse can be undertaken either on-site or off-site.
- 7.3.2. Where possible, excavated earthworks materials and soils arising from the Project will be stockpiled on-site and reused within the Project.

Recycling

- 7.3.3. The aim is to reuse site-won materials by recycling them into an alternative form that can be used for construction purposes (for example crushing concrete, brick or other inert wastes to produce aggregate material). By recycling on-site, as far as practicable, the quantity of waste requiring off-site management is reduced and carbon emissions associated with transportation are eliminated.
- 7.3.4. Recycling may also be achieved by utilising materials with a recycled content, such as recycled aggregates produced off-site.

Recovery

- 7.3.5. This generally aims to recover energy from waste which cannot otherwise be reused or recycled. This may include waste materials such as hazardous liquids or solids that can be sent to energy from waste facilities.
- 7.3.6. Recovery may also include the beneficial use of materials on land for restoration (e.g. deposit for recovery).

Disposal

- 7.3.7. The least preferred option in the waste hierarchy is a final disposal route such as landfill or incineration without energy recovery. Some waste streams would inevitably end up with such a solution.
- 7.3.8. When placing waste disposal contracts, the contractor shall consider the implications of long distance travel in terms of health and safety risk, commercial terms and increased emissions from vehicles.
- 7.3.9. The contractor shall ensure the pre-treatment of all hazardous and non-hazardous wastes prior to disposal to landfill. The methods of pre-treatment would enable the waste to meet the 'three-point test':
- a. It must be a physical, thermal, chemical or biological process including sorting.
 - b. It must change the characteristics of the waste.
 - c. It must do so in order to:
 - i. Reduce its volume.
 - ii. Reduce its hazardous nature.

iii. Facilitate its handling.

iv. Enhance its recovery.

7.3.10. Source segregation can be seen as a pre-treatment option and as such can be applied to waste generation on site including general waste and arisings, and would take place for the Project.

7.3.11. The contractor shall ensure that a declaration stating the pre-treatment method applied to the waste is appended to any WTN for non-hazardous waste being sent for disposal.

7.4. Site waste management measures

7.4.1. Where it is necessary to transport waste to and from the site, this will be undertaken in compliance with the Waste (England and Wales) Regulations 2011 (as amended) (Ref 1-5) including: transporting waste via registered carrier, disposal to appropriately licensed sites and maintenance of appropriate waste transfer documentation. All contractors will be required to apply the principles of the waste hierarchy and investigate opportunities to minimise waste generation.

7.4.2. The disposal of all waste or other materials removed from the site would be undertaken in accordance with legal requirements. Any waste effluent (including effluent to be discharged into the local sewerage network) would be tested and where necessary treated and disposed of at an appropriately licensed facility by a licensed specialist contractor.

7.4.3. The risk of infestation by pests or vermin on-site would be minimised by making adequate arrangements for the disposal of food and other material potentially attracting pests. Where there is a local infestation, the relevant local authorities would be consulted.

7.4.4. The contractor shall adopt best practice measures set out in construction industry guidance to reduce the potential impacts from material resources and waste and to be set out in the SWMP. This may include, for example, guidance from the Considerate Constructors Scheme (“CCS”), WRAP and the Construction Industry Research and Information Association (“CIRIA”). On-site waste management measures to adhere to the waste hierarchy, and best practice which should be employed on-site, are presented in **Table 6** and **Table 7** respectively.

Table 6: On-site Waste Management Measures to Adhere to the Waste Hierarchy

Site Waste Management Measure	Waste Hierarchy Principle	Phase	Waste Stream	Description
Supplier take-back	Reduce/prevention	Construction	Construction Materials	Agreements with material suppliers to reduce the amount of packaging or to participate in a packaging take-back scheme. The contractor could set up a take-

Site Waste Management Measure	Waste Hierarchy Principle	Phase	Waste Stream	Description
				back arrangement with suppliers in order to prevent packets and packaging being broken up and placed in skips.
Just in time deliveries	Reduce/prevention	Construction	Construction Materials	The contractor should implement a just-in-time delivery system in order to try and avoid the over-ordering of materials and stockpiling. This will prevent surplus materials from risk of damage and disposal as waste.
Standardisation	Reduce/prevention	Construction	Construction Materials	Use of standard size components in design to eliminate waste at source where possible to do so. The contractor should implement standard sizes for most items ordered in order to avoid cutting on-site; materials are to be ordered in size in order to allow for minimum waste production.
Pre-assembly and pre-fabrication	Reduce/prevention	Demolition and construction	Construction Materials	Throughout the design and construction phases of the Project, emphasis should be on pre-assembly and pre-fabrication of elements wherever practicable to minimise on-site waste generation and packaging waste.
Reuse of materials on-site wherever feasible	Reuse	Demolition and construction	Multiple	For example, the Government has set broad targets for the use of recycled and secondary aggregates, and in keeping with best practice, the contractor will be

Site Waste Management Measure	Waste Hierarchy Principle	Phase	Waste Stream	Description
				required to maximise the proportion of materials recycled.
Concrete crushing	Reuse	Demolition and construction	Concrete and brick	In keeping with guidelines set out by the Government for reclaiming aggregates, deconstructed concrete (if appropriate) will be taken off-site for crushing and reuse. Where practicable, all concrete and brick elements will pass through crushing machines and the residual material will be recycled for use on-site in line with best practice.
Wheel washers and rainwater harvesting systems	Reuse	All	Liquids	The use of recycling water systems such as wheel washers and rainwater harvesting systems for use in equipment and vehicle washing will be investigated in order to maximise reuse and to reduce energy consumption.
Reuse and recycling of materials off-site	Reuse	All	All	Where reuse on-site is not practical (for example through use of an off-site waste segregation facility and re-sale for direct reuse or reprocessing).
Segregation of waste at source	Recycling	All	All	Waste segregation strategies will be developed and implemented in-line with the overarching plan for logistics for the site. Substances hazardous to health, for example gypsum/plasterboard

Site Waste Management Measure	Waste Hierarchy Principle	Phase	Waste Stream	Description
				and liquid waste will be segregated.
Colour coding and signage	Recycling	All	All	Skips to be colour coded and signposted to reduce risk of cross contamination and covered to prevent dust and debris blowing around the site, these will be cleared on a regular basis.
Staff training	All	All	n/a	All staff on-site will be appropriately trained on how to reuse materials, prevent and recycle waste.

Table 7: Best Practice On-site

Waste Management Measures	Waste Stream	Description
Appropriate concrete storage used to minimise dust and reduce vehicle movement	Concrete	Any processed concrete material should be stockpiled, and any dust generated shall be controlled with covers or dampened with water.
Surface drainage, ground waste seepage and dewatering of the Site	Liquid waste	All surface drainage and dewatering of the Site should pass through a settlement tank prior to entering the foul water sewer. Discharge arrangements into the foul water sewer will be agreed with the local sewerage company.
Liquid disposal	Liquid waste	The contractor will check that any water, which may have come into contact with contaminated materials will be disposed of in accordance with the Water Resources Act 1991 (Ref 1-14), and to the satisfaction of the Environment Agency or the local sewerage company.
Clearing of Containing Materials (ACMs)	Asbestos Containing Materials	In line with the Control of Asbestos Regulations 2012 (Ref 1-15), Asbestos Containing Materials (“ACMs”) present on-site will be appropriately removed and disposed of prior to the start of the

Waste Management Measures	Waste Stream	Description
		demolition by a suitable qualified contractor.
Sealing of containers	All hazardous materials	All hazardous materials including chemicals, cleaning agents, solvents and solvent containing products will be properly sealed in containers (of 110% volume of the materials stored) at the end of each day prior to storage in appropriately protected and bunded storage areas.
Classification and management of potentially contaminated materials	All hazardous materials	Should any potentially contaminated materials be identified for disposal during the construction phases, this waste will be classified in accordance with the Waste Classification Technical Guidance (WM3) (Ref 1-16).
Audit trail: Transportation and disposal	All waste streams	The contractor will dispose of all waste or other materials removed from the Site in accordance with regulatory requirements and provide evidence that all waste has been deposited or transferred to the correct place and by appropriately licensed contractors (i.e. an audit trail). WTNs will be used to document waste production within the confines of the site and movement to external facilities. These WTNs will detail the type of waste, waste volume, waste classification, contractor, ultimate disposal route and other necessary information. Records will be updated documenting that all waste transferred or disposed of has been correctly processed with evidence of signed WTNs that will be kept on-site for inspection whenever requested by the Environment Agency.
Storage	All waste streams	The storage of potentially polluting plant and materials will be limited as far as possible. For example, the plant could be refuelled from visiting fuel trucks rather than from on-site fuel bowsers. All spoil will also be stored on impermeable surface areas, with bunding, in order to prevent potential contaminated material coming into contact with flora or fauna. The bunded areas will also prevent contact with water, which could allow contaminants to seep into the local

Waste Management Measures	Waste Stream	Description
		drainage network, or leach to groundwater, and have damaging effects on both humans and wildlife.
Dampening down of surfaces	All waste streams	Dampening down of surfaces during spells of dry weather and brushing/water spraying of heavily used hard surfaces/access points across the site as required.
Provision of on-site waste burning	All waste streams	Burning of waste or unwanted materials will not be permitted on-site.
Instruction and training	All waste streams	The contractor will incorporate the SWMP requirements into the site induction and the contractor shall provide on-site instruction of appropriate separation, handling, recycling, reuse and return methods to be used by all parties at all appropriate stages of the Project.

- 7.4.5. In addition to the above measures, the contractor shall implement the following waste management procedures:
- All waste containers shall be secure and ensure that no waste is allowed to escape.
 - All waste containers shall be clearly labelled using a colour coding system so that users know what wastes can be placed in each container. Waste containers shall be appropriately colour coded using generic colour codes. An example is shown below:

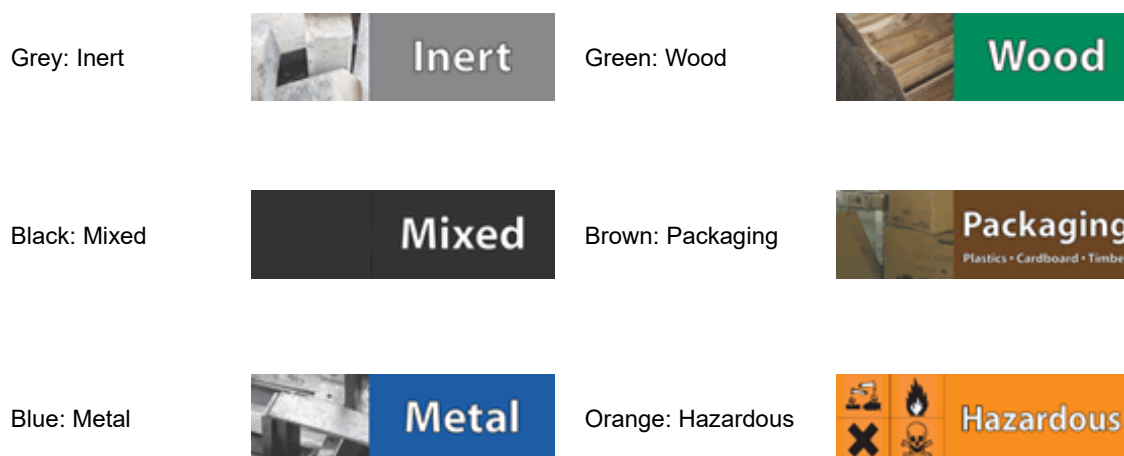

White: Gypsum



Gypsum

- c. Lockable storage shall be provided for all hazardous waste.
- d. All waste containers shall be sited at least 10m away from watercourses, ditches and other areas of environmental sensitivity.
- e. Liquid wastes shall be stored in enclosed/lidded containers and stored within a suitable bunded area, or otherwise provided with secondary containment.
- f. Separate containers shall be provided for each type of hazardous waste.
- g. Sewage from the site offices/compounds would drain to septic tank and be collected by a suitable specialist waste contractor.
- h. Portable toilet facilities on-site (Portaloos etc.) shall be emptied by the facility provider as per their service agreement.

7.5. Waste Carriers and Facilities

- 7.5.1. The contractor shall manage all waste generated on the Project in accordance with legal requirements. The contractor shall record details of the proposed waste carrier for each waste stream in the registration table, with registered waste carrier details appended to the SWMP. An example table for demonstrating waste carrier registration is available in **Appendix A**.
- 7.5.2. The contractor shall ensure that the following information is recorded for all waste facilities used:
 - a. Contractor's name.
 - b. Date(s) of waste removal.
 - c. Type(s) of waste removed (i.e. Non-hazardous waste, hazardous waste, inert (specify)).
 - d. Method of treatment, recovery or disposal (i.e. Reuse, recycling, incineration, landfill etc.).
 - e. Volume or weight of waste removed.
 - f. Recovery rate achieved.
 - g. Costs associated with waste removal, transport and treatment, including Landfill Tax charges where applicable.

7.6. Waste Documentation

- 7.6.1. All waste documentation will be retained at the main site compound and, following completion of construction works, at the contractor Head Office. This includes:
 - a. SWMP (to be retained for two years after completion of the relevant construction works).

- b. Waste transfer documentation (to be retained for two years for WTNs and three years for HWCNs).
- c. Copies of any exemptions or permits.
- d. Copies of any waste carrier and disposal site licenses.

Waste Transfer Notes (WTNs)

- 7.6.2. The contractor shall ensure that all movements of waste from site are accompanied by a WTN, which will detail specific information. The contractor's Site Materials and Waste Manager or other competent person shall check that each WTN contains the following:
- a. The name of the person receiving the waste and what they are authorised to do with that waste (e.g. a Registered Waste Carrier can only transport waste).
 - b. Type of waste.
 - c. The Standard Industrial Classification of Economic Activities ("SIC") code.
 - d. The six-digit European Waste Catalogue ("EWC") code.
 - e. Address of the producing site and details of the waste producer.
 - f. Waste carrier's details including registration number.
 - g. Quantity of waste.
 - h. How it is contained (e.g. 8 cubic yard skip).
 - i. Address of the receiving site (e.g. landfill) and the environmental permit or exemption no. associated with the receiving site.
 - j. The date to which the WTN applies.
 - k. If the material is non-hazardous waste and it is destined for disposal directly to landfill, pre-treatment must have been applied and a declaration detailing the treatment applied appended to the WTN.
 - l. A declaration that the waste has been treated in line with the requirements of the waste hierarchy.
- 7.6.3. The site representative signing the WTN shall ensure all WTNs are kept for a minimum period of two years (for non-hazardous waste).
- 7.6.4. By signing a WTN, the site representative is confirming that all the details are correct and that the material is to be sent by a registered waste carrier to a suitably licensed receiving site, permitted to receive that type of waste. The signature is binding of this fact and completes the WTN as a legal document.
- 7.6.5. The Site Materials and Waste Manager or other competent person signing the WTN shall additionally ensure that the registered waste carrier is using a suitable vehicle with adequate, covered containment for the waste.

Hazardous Waste Consignment Notes (HWCN)

- 7.6.6. The contractor shall ensure that a HWCN is completed for every movement of hazardous waste. Prior to signing, the Site Materials and Waste Manager or another competent person shall ensure that the HWCN includes:
- HWCN code (unique identification code).
 - SIC Code.
 - Name and address of the site from which the waste is being moved.
 - Date of removal.
 - Type of waste produced, including the quantity and the EWC code.
 - The name of the person who is receiving the waste and what they are authorised to do with that waste e.g. Registered Waste Carrier can only transport waste.
 - The final disposal site that is authorised to accept the waste.
 - Retention period for hazardous waste.
- 7.6.7. The contractor shall retain a copy of the HWCN for a minimum of three years.

7.7. Fly-tipping

- 7.7.1. Fly-tipping of waste on or adjacent to ongoing construction projects can be a significant issue.
- 7.7.2. Should waste be fly-tipped on the site, the contractor shall have a duty of care to ensure it is dealt with safely and disposed of correctly, even though not the producer of the waste. The contractor shall report any instance of fly-tipping to the relevant authorities.

7.8. Reporting and Auditing

- 7.8.1. The effectiveness of the SWMP will depend upon the enforcement of its requirements on-site by the nominated Site Materials and Waste Manager and Project Manager. Responsibility for the formal recording of waste movements lies with the Site Materials and Waste Manager or Project Manager.
- 7.8.2. The contractor shall maintain a record of all materials that come on to site. The quantity of reused, recycled and secondary aggregate shall be recorded, alongside details of the supplier, the producing facility and records that demonstrate that the material meets all relevant technical and regulatory requirements. An example table for recording materials imported to site is available in **Appendix B**.
- 7.8.3. The contractor shall maintain a record of all wastes that are removed from the site and their management route. Each waste management contractor shall provide details of the types and quantities of waste removed from the site, the receiving waste management facility and the associated recycling, recovery and disposal rates for each waste stream. An example table for recording waste management is available in **Appendix C**.

- 7.8.4. The contractor shall monitor, and record details of the wastes placed in all waste receptacles to ensure that contamination has not occurred.
- 7.8.5. The contractor shall continually review the types of surplus materials and waste being produced and change the site set up to minimise wastage rates and maximise reuse or recycling.
- 7.8.6. The Client or its representatives may carry out ‘spot checks’ in relation to the completeness of any WTNs and any HWCNs.
- 7.8.7. If any problems are identified during the construction of the Project in relation to exceeding the expected SWMP waste stream quantities, failure to meet stated KPI targets, or issues relating to the cost effective and legal transfer of waste, then the contractor site representative shall escalate these to the Project Manager for further discussion on the best solution. This may trigger a review of the SWMP.
- 7.9. Review of SWMP
- 7.9.1. The contractor shall review the SWMP at least once every six months during the construction of the Project to ensure that KPI targets are being achieved and that realistic solutions are provided for unplanned events or abnormal wastes. The contractor shall also review the SWMP if there is any significant change in the Project. These reviews will involve the completion and submission of a monitoring report to the Client (or its representative) in an agreed format.
- 7.10. Additional Duty of Care Checks
- 7.10.1. The contractor shall periodically, at intervals to be determined, follow waste loads to confirm that the waste has been transferred to the place stated on the WTN, with any irregularities investigated immediately, and reported as an environmental incident. Action may involve termination of contract and/or notification to the Environment Agency.
- 7.11. Site Inspections
- 7.11.1. The Site Manager or nominated deputy shall undertake a daily inspection of the construction areas including all areas used for waste management. Any issues shall be recorded in the daily log along with any corrective action taken.
- 7.12. Closure Reporting
- 7.12.1. Within three months of the completion of works under a contract, the contractor shall submit a Waste Management Closure Report to the Client (or their representative) to demonstrate the effective implementation, management and monitoring of construction materials and waste during the construction lifetime of the Project.

8. References

- Ref 1-1 European Union, (2008), Directive 2008/98/EC of the European Parliament and of the Council of 19 November 2008 on Waste and Repealing Certain Directives.
- Ref 1-2 His Majesty's Stationary Office (HMSO), (2008) The Site Waste Management Plans Regulations 2008.
- Ref 1-3 HMSO, (2013). The Environmental Noise, Site Waste Management Plans and Spreadable Fats etc. (Revocations and Amendments) Regulations 2013 (S.I. 2013/2854), regs. 1, 2(c).
- Ref 1-4 HMSO, (1990); Environmental Protection Act 1990 as amended.
- Ref 1-5 HMSO, (2011), Waste (England and Wales) Regulations 2011 as amended.
- Ref 1-6 Defra, (2018) Waste Duty of Care Code of Practice.
- Ref 1-7 Control of Pollution (Amendment) Act 1989.
- Ref 1-8 HMSO, (2016), The Environmental Permitting (England and Wales) Regulations 2016.
- Ref 1-9 WRAP, (2007), Waste Recovery Quick Wins. Improving Recovery Rates without Increasing Costs.
- Ref 1-10 HMSO, (2013), WEEE Regulations 2013.
- Ref 1-11 Department for Environment, Food & Rural Affairs, (2021), The Waste Management Plan for England.
- Ref 1-12 IEMA, (2020), Guide to: Materials and Waste in Environment Impact Assessment, Guidance for a Proportionate Approach.
- Ref 1-13 Department for Environment, Food & Rural Affairs, (2011), Guidance on Applying the Waste Hierarchy.
- Ref 1-14 HMSO, (1991); Water Resources Act 1991.
- Ref 1-15 HMSO, (2012); Control of Asbestos Regulations 2012.
- Ref 1-16 Environment Agency, Scottish Environment Protection Agency, Natural Resources Wales, (2021); Guidance of the Classification and Assessment of Waste (1st Edition v1.2 GB) Technical Guidance (WM3).
- Ref 1-17 Environment Agency and Department for Environment, Food & Rural Affairs (2020). Check if you need an Environmental Permit.

9. Glossary and Abbreviations

Term	Definition
CCS	Considerate Constructors Scheme
CIRIA	Construction Industry Research and Information Association
Duty of Care checks	Checks to ensure that only authorised persons transfer waste, and that the waste is managed legitimately, including checks on: <ul style="list-style-type: none"> a. the waste carrier's registration certificate; b. the waste broker's registration certificate (if used); and c. the environmental permits for waste management facilities or proof of permit exemption.
Environment Agency (EA)	The main environmental regulatory body in England.
European Waste Catalogue (EWC) code	A six-digit number used to classify a particular waste stream.
Exempt activities	Activities not requiring an environmental permit (an exemption will require registration).
Hazardous Waste Consignment Note (HWCN)	A document that accompanies the movement of any hazardous waste from production (cradle) to disposal (grave).
Hazardous waste	Waste with hazardous properties.
HMSO	His Majesty's Stationary Office.
IEMA	Institute of Environmental Management and Assessment
KPI	Key Performance Indicator
Non-hazardous waste	Waste which does not display any of the hazardous properties listed in Annex III of The Hazardous Waste (England and Wales) Regulations 2005 (as amended).
OSWMP	Outline Site Waste Management Plan
Contractor	Appointed to deliver a project by the Client.
Registered Waste Carrier	A person who holds a registration certificate from the Environment Agency to transport waste.
SIC Code	Standard Industrial Classification of Economic Activities Code

Term	Definition
SWMP	Site Waste Management Plan - sets out how material resources and waste will be managed and controlled at all stages during a construction project.
WEEE	Waste Electrical and Electronic Equipment
WRAP	Waste and Resources Action Programme
WTN	Waste Transfer Note

Annex B – Construction Materials Imported to Site

Client Name:		<u>Key Performance Indicator:</u> Achieving a set percentage (by weight) of materials imported to site for use within the Project containing alternative (reused, recycled or secondary) content, for those applications where it is technically and economically feasible to substitute these alternatives to primary materials.
Project		
Contractor:		

Material / Aggregate	Material Density (tonnes/m ³)	Quantity Required for Construction	Quantity to be Imported to Site (tonnes)	Supplier	Supplier Facility	Facility Permit / Licence / Exemption Number	Evidence of Compliance With Specification/Protocol	Recycled Content (% by Weight)
Overall proportion of reused, recycled and secondary content (% (by weight))								

Annex C – Waste Management

Client Name:		Key Performance Indicators: Achieving a set percentage (by weight) for recovery of non-hazardous C&D waste. Such a target would specifically exclude naturally occurring materials with EWC Code 17 05 04 (soil and stones other than those mentioned in 17 05 03* (soils and stones containing dangerous substances)). Recovery is deemed to include reuse, recycling and other recovery e.g. energy recovery.
Project:		
Contractor:		

Waste Type	EWC Code	Quantity (tonnes)	On-site		Off-site			Waste Carrier	Off-site Waste Management Facility
			Reused On-site	Recycled On-site	Reused Off-site	Recycled Off-site	Recovered Off-site		

Non-hazardous construction and demolition waste recovered	% (by weight)
--	---------------

Appendix B: Outline Soils Management Plan



Immingham Green Energy Terminal

TR030008

Volume 6

Appendix B – Outline Soil Management Plan

Planning Act 2008

Regulation 5(2)(a)

Infrastructure Planning (Applications: Prescribed
Forms and Procedure) Regulations 2009 (as
amended)

March 2024

Infrastructure Planning

Planning Act 2008

The Infrastructure Planning (Applications: Prescribed Forms and Procedure) Regulations 2009 (as amended)

Immingham Green Energy Terminal Development Consent Order 2023

Appendix B – Outline Soil Management Plan

Regulation Reference	APFP Regulation 5(2)(a)
Planning Inspectorate Case Reference	TR030008
Application Document Reference	TR030008/APP/6.5
Author	Associated British Ports Air Products BR

Version	Date	Status of Version
Revision 1	21 September 2023	DCO Application
Revision 2	26 March 2024	Deadline 2

Table of Contents

1.	Introduction.....	1
1.1	Background	1
1.2	Legislation and Best Practice	1
1.3	Relevant Management Plans during Works.....	2
2.	Proposed Works	3
2.1	General.....	3
2.2	Impacts on Soil Resources	3
2.3	Soil Resources at the Site	4
3.	Outline Proposals for Soil Management and Handing	8
3.1	General Principles	8
3.2	Pre-Construction Activities.....	8
3.3	Preparation	9
3.4	Soil stripping controls and checks	9
3.5	Topsoil stripping.....	9
3.6	Subsoil stripping	12
4.	Soil Storage.....	14
4.1	Stockpile Construction.....	14
4.2	Management of Stockpiles	16
5.	Soil Reinstatement	17
5.1	General.....	17
5.2	Subsoil.....	17
5.3	Topsoil	18
5.4	Off-Site Reuse / Disposal	19
6.	References	21

Plates

Plate 1:	Locations with Topsoil during the 2023 Ground Investigation.....	5
Plate 2:	Stripping with excavators and dump trucks: Removal of topsoil from a strip (Ref 1-7).....	12
Plate 3:	Stripping with excavators and dump trucks: Removal of subsoil from a strip (Ref 1-7).....	13
Plate 4:	Soil Stockpiling: Method 2 (Ref 1-5).....	15
Plate 5:	Soil Stockpiling: Method 1 (Ref 1-5).....	15
Plate 6:	Soil Replacement with Excavators and Dump Trucks: Subsoil Layer (Ref 1-7).....	18
Plate 7:	Soil Replacement with Excavators and Dump Trucks: Topsoil Layer (Ref 1-7).....	19

Tables

Table 1: Summary of Topsoil Encountered in the West Site 4
Table 2: Summary of ALC Gradings for the Site 6

1. Introduction

1.1 Background

- 1.1.1 This Outline Soil Management Plan (“SMP”) sets out the general strategy for the management of soil during the works at the Site and details the arrangements for areas where soil material shall be stripped and stored before being returned to its original location or reused elsewhere on the Site.
- 1.1.2 This Outline SMP is based on the guidance provided in:
- Department for Environment, Food and Rural Affairs (Ref 1-5) Construction Code of Practice for the Sustainable Use of Soils on Construction Sites.
 - Ministry of Agriculture Fisheries and Food MAFF (Ref 1-7) Good Practice for Handling Soils.
 - British Standards Institution (Ref 1-2) BS 3882:2015 – Specification for Topsoil.
 - Institute of Environmental Management (IEMA) A New Perspective on Land and Soil in Environmental Impact Assessment (Ref 1-11).

1.2 Legislation and Best Practice

- 1.2.1 An Outline Site Waste Management Plan (“OSWMP”) has been prepared for the works as part of the overall Outline Construction Environmental Management Plan (“CEMP”) [TR030008/APP/6.5].
- 1.2.2 Topsoil management shall adhere to the DEFRA Construction Code of Practice for the Sustainable Use of Soils on Construction Sites (Ref 1-5) which details approaches and techniques for:
- The identification of soil resources at an early stage in the development process.
 - Improved planning of soil use.
 - Better level of soil management during project implementation, including sustainable use of surplus soil.
 - The maintenance of soil quality and function both on and offsite.
 - Avoidance of soil compaction and erosion (with a consequent reduction in flooding and water pollution).
 - Improved knowledge and understanding of soil at all levels in the construction industry, including soil amelioration techniques.
 - Areas of soil to be protected from earthworks and construction activities.
 - The areas and types of topsoil and subsoil to be stripped, haul routes and stockpile locations.
 - The methods for stripping, stockpiling, re-spreading and ameliorating landscape soils.

1.3 Relevant Management Plans during Works

1.3.1 The strategy set out in this Outline SMP document where applicable will comply with the requirements of the following management plans prepared for the works:

Outline Asbestos Management Plan (“AMP”)

1.3.2 The Outline Asbestos Management Plan (**Annex E**) for the Site prepared for the works sets out the procedures and practices to be implemented in the event that asbestos containing material (“ACM”) is encountered during the works.

Outline Remediation Strategy

1.3.3 An Outline Remediation Strategy (**Appendix 21.C [TR030008/APP/6.4]**) has been prepared for the Site. The document sets out the procedures for dealing with any contamination that may be encountered during the main works at the Site. The Outline Remediation Strategy also provides the details of the required geo-environmental monitoring during the works.

2. Proposed Works

2.1 General

2.1.1 The main elements of the Project includes a process plant, storage tanks and pipe racks, much of which are expected to be settlement sensitive. The ground surface on the finished Site is expected to be occupied by a combination of plant, roads, paved areas and gravel areas.

2.1.2 The Site is split up into the following areas:

- a. Terminal comprising a jetty, topside infrastructure and related landside infrastructure including access ramp (**Work No. 1**).
- b. A corridor between the jetty and Laporte Road to support a jetty access road, a pipe-rack supporting the ammonia import pipeline to the East Site and a reserved corridor for future pipelines including CO₂ (**Work No. 2**).
- c. East Site on which the ammonia storage and hydrogen production would be undertaken (**Work Nos. 3, 4 and 5**).
- d. Pipeline and Utility Corridors between the East and West Sites for the transfer of ammonia, hydrogen, nitrogen and utilities (**Work No. 6**).
- e. West Site, where hydrogen production, hydrogen liquefaction, storage and unloading would be undertaken (**Work No. 7**).
- f. Temporary Construction Areas for laydown and construction compounds off Queens Road (**Work No. 8**) and Laporte Road (**Work No. 9**).
- g. Four areas on Kings Road to enable the temporary modification of overhead cables and temporary remove of signage, lampposts and street furniture (**Work No. 10**).

2.1.3 The details of the anticipated activities during works at the Site are presented in the Outline CEMP.

2.2 Impacts on Soil Resources

2.2.1 Construction related activities can result in some of the most significant adverse impacts on soil properties and soil quality. Construction activities and mishandling of soil can result in damage to soil structure and reduce the soil's ability to perform its functions. The IEMA Guide (A New Perspective on Land and Soil in Environmental Impact Assessment) (Ref 1-11) considers the following soil functions:

- a. "Biomass (food, fibre and fuel) production"
- b. "Ecological habitat and platform for soft infrastructure (i.e. green infrastructure)"
- c. "Interactions with the atmosphere: as a component of the carbon and nitrogen cycles"
- d. "Interactions between land and the atmosphere: as a component of the hydrological cycle"

- e. “Preservation of archaeological, cultural heritage, community benefits and geodiversity”
- f. “A source of materials”

2.2.2 The susceptibility of soil resources to loss and damage has necessitated the need for adequate mitigation to be put in place during construction works through the Outline SMP.

2.2.3 Adverse effects on soils can occur in a number of ways:

- a. Accidental spillages or the use of chemicals resulting in the contamination of soil resource.
- b. The mixing of topsoil and subsoil reducing the overall soil quality.
- c. Storing of topsoil in areas of differing soil type.
- d. Off-site disposal of soils due to the mixing of soil and construction waste or contaminated materials which require treating before reuse or ultimately disposed of at landfill.
- e. The use of heavy machinery or the storage of construction materials can result in the over-compaction of the soil.
- f. The use of impermeable materials to cover soils, which can result in detrimental impacts on the soils’ biological, chemical and physical properties. In addition, this can result in certain geotechnical parameters being altered such as drainage characteristics and structure.
- g. Destruction of topsoil structure by incorrect storage, e.g. Over high stockpiles (in excess of 2m high) compressing soil structure.

2.2.4 Adverse effects on soils can be mitigated by adopting high standards of soil handling, storage and management during construction, and by avoiding the creation of bare areas of permanently exposed soil that would be vulnerable to erosion processes.

2.3 Soil Resources at the Site

2.3.1 The 2023 ground investigation (**Appendix 21.B [TR030008/APP/6.4]**) identified topsoil at a number of locations within the West Site only. A summary of the encountered topsoil is provided in **Table 1** and shown in **Plate 1**. An additional ground investigation undertaken within the Pipeline Corridor (Work No.6) did not identify any topsoil at the locations investigated (all ‘soils’ comprised made ground only [see section 4.3 of **[REP1-044]**]).

Table 1: Summary of Topsoil Encountered in the West Site

Location	Thickness Range (m)	Typical Description
West Site	0.15 – 0.6	Grass over firm dark brown slightly sandy CLAY with frequent rootlets.

Source: Ref 1-1

Plate 1: Locations with Topsoil during the 2023 Ground Investigation

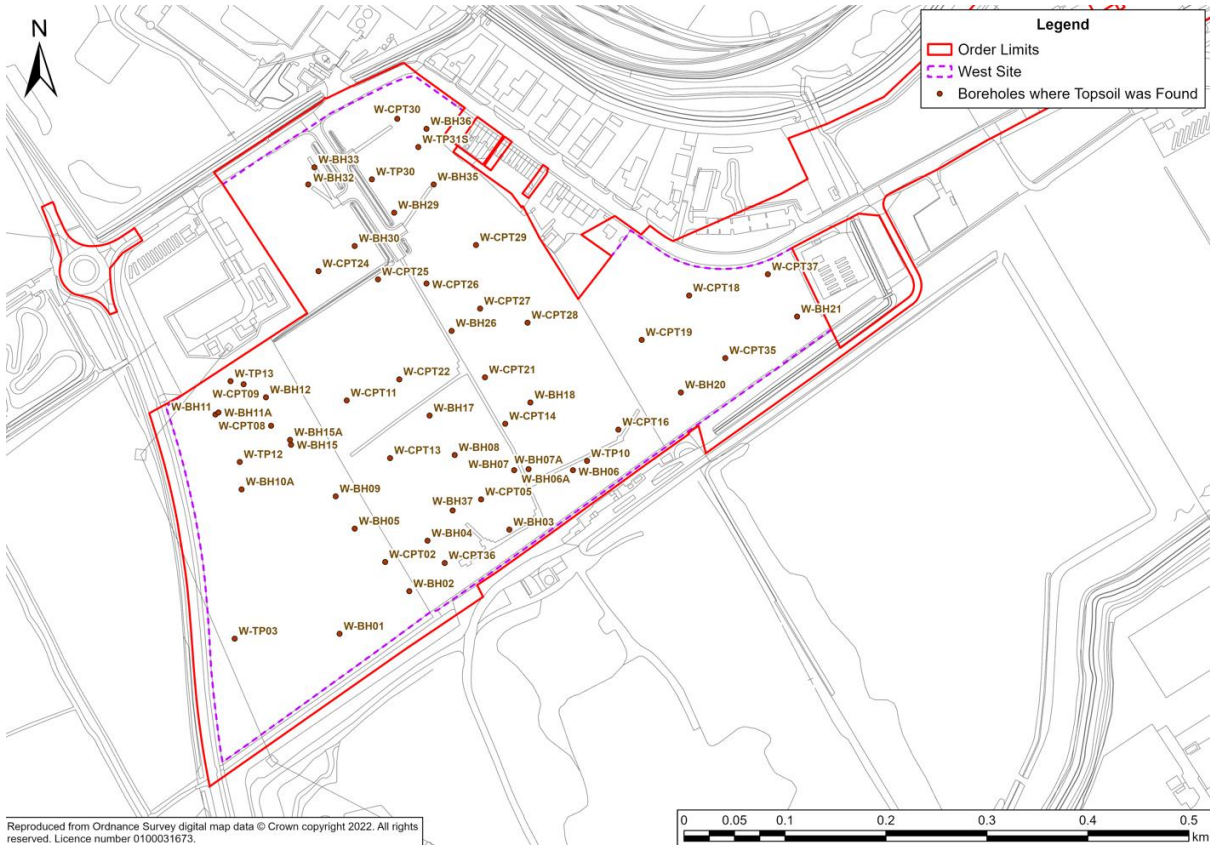

2.3.2 A summary of the Agricultural Land Classification for the Site is provided in **Table 2**. As the Natural England Provisional ALC Map (Ref 1-8) indicated the presence of Grade 3 land within the Site, an ALC Survey was undertaken by Reading Agricultural Consultants (Ref 1-10) within the West Site and the Laporte Road Temporary Construction Area.

Table 2: Summary of ALC Gradings for the Site

Location	ALC Grade	ALC Survey Results
East Site (Work No. 3, 3-A, 4, 5 and 5-A)	The East Site is designated as Grade Urban.	No survey undertaken.
West Site (Work No. 7, 7-A, 7-B, 7-C and 7-D).	Most of the West Site is designated as Grade 3. The land has not been subdivided into Grades 3a or 3b. A small area of land parallel to and including the properties on Queens Road is designated as Grade Urban.	The ALC Survey indicates the West Site is designated as Grade 3b.
Pipeline Corridor, Jetty Access and Pipe-Rack Corridor and Queens Road Temporary Construction Area (Work No. 2, 6 and 8)	The Pipeline Corridor and Jetty Access Road Corridor are designated as Grade Urban.	No survey undertaken.
Laporte Road Temporary Construction Area (Work No. 9)	The eastern half of the Laporte Road Temporary Construction Area is designated as Grade 3, but not subdivided into Grades 3a or 3b, and the western half is designated as Grade Urban.	The ALC Survey within the thin strip of land in the Laporte Road Temporary Construction Area, adjacent to the Jetty Access and Pipe-Rack Corridor, indicates the land is classified as Grade 3b.

Source: Ref 1-8 and Ref 1-10.

- 2.3.3 Cranfield Soils Map (Ref 1-3) indicates the soils underlying the entire Site are described as “*loamy and clayey soils of coastal flats with naturally high groundwater*” with naturally wet drainage. It is noted that applied nutrients, waste and pesticides to the land may be a potential risk to water resources, particularly due to the presence of shallow groundwater and drainage ditches.
- 2.3.4 The Reading Agricultural Consultants (Ref 1-10) report indicates the soils are classified as soil association Newchurch 2 which “*comprise deep, stoneless, clayey and silty clay soils*”. The Newchurch 2 soil is calcareous. It is noted by Reading Agricultural Consultants (Ref 1-10) that the soils require drainage for groundwater control. The samples of topsoil were described as a firm or silty clay with no stones, moderately well-developed structure with medium angular block peds. It is noted that there is faint mottling in the topsoil. The upper subsoil was described as a very firm mottled clay with coarse angular blocky peds. The lower subsoil horizons comprised a mottled, gleyed stoneless clay.

- 2.3.5 The potassium and magnesium levels in the Newchurch 2 soils are generally satisfactory but phosphorus levels are often low when poor-quality grassland is brought into arable use. Manganese deficiency sometimes occurs on Newchurch soils.
- 2.3.6 Soil Reports by the National Soil Resources Institute (“NSRI”) have not been obtained for the Site.

3. Outline Proposals for Soil Management and Handing

3.1 General Principles

- 3.1.1 To mitigate and reduce the impacts on soil resources (topsoil and subsoil) during the works at the Site, the following guidelines will be adhered to:
- a. Vehicle and plant movements within the working areas should be restricted to defined areas.
 - b. Multiple handling of soils should be avoided and where possible, soils should be moved directly from the source area to the placement area.
 - c. During handling, mixing of soils of different functions such as topsoil and subsoil should be avoided.
 - d. Handling of soils should not occur during or immediately after periods of prolonged or heavy rainfall.
 - e. Plant employed for soil handling should only operate in suitable ground conditions to avoid damaging the soil structure.

3.2 Pre-Construction Activities

- 3.2.1 Prior to undertaking any bulk stripping of soils, the soils shall be subject to an analytical testing regime to assess the quality of the soil against BS 3882:2015 – Specification for topsoil and requirements for use (Ref 1-2).
- 3.2.2 The specification for soil testing shall include the following analyses:
- a. Visual examination (including description of soil structure, consistency and foreign matter).
 - b. Particle size distribution (including stone content).
 - c. Geochemical testing.
 - d. Ph and salinity values.
 - e. Major plant nutrients content.
 - f. Organic matter content.
 - g. Maximum levels of potential contaminants (e.g. Heavy metals, hydrocarbons, cyanide and phenols).
- 3.2.3 The sampling of soil for analysis shall be undertaken in line with the specification by suitably qualified personnel to the soil's full depth, with separate samples being obtained from each soil area and contrasting land use within them.
- 3.2.4 To provide an accurate representation for each sampling area, the mixing together of several incremental samples taken across a certain area shall be undertaken using the random 'figure of W' or rectilinear grid sampling methodologies presented within DEFRA's Code of Practice (Ref 1-5).

3.2.5 All samples obtained shall be submitted to a suitably qualified, quality assured laboratory and tested for parameters in line with the specification. Permeability and porosity testing shall be undertaken where such information will assist in establishing soil quality, for example to establish its required performance.

3.2.6 Where trenches are being excavated (i.e. for utility diversion or archaeological surveys), the depth of soil encountered shall be recorded at each location where soil stripping is to be undertaken, to ensure that the same thickness of topsoil is replaced at the end of the construction works.

3.3 Preparation

3.3.1 Where soil stripped is to be placed at a location different from the source area, soil stripping shall be undertaken only after analysis of the soil survey results has taken place.

3.3.2 Areas where soil stripping is required to be undertaken shall be demarcated and fenced ahead of any major construction plant, vehicles or machinery entering the works area.

3.3.3 Temporary ditches shall be excavated, where required, to act as cut-off drains to drain surface water from adjacent fields.

3.3.4 Stockpiles of soil shall be located away from watercourses or other water features, to reduce the potential risk of pollution from suspended solids.

3.4 Soil stripping controls and checks

3.4.1 Prior to undertaking any soil stripping operations, the following checks shall be undertaken:

- a. Ensure all necessary pre-construction surveys have been completed.
- b. Follow and implement all identified mitigation requirements for the location and method of stripping.
- c. Ensure adequate stockpile storage designation areas are prepared.
- d. Check whether an archaeological watching brief is required by a suitably qualified archaeologist to supervise any soil stripping operations.

3.5 Topsoil stripping

3.5.1 The following principles shall be adhered to during the stripping and handling of topsoil across all parts of the Scheme, in line with DEFRA's Code of Practice (Ref 1-5):

- a. Any surface vegetation shall be removed by blading off, by scarification and raking, or by kill off methods such as the application of a suitable non-residual herbicide applied not less than two weeks before stripping.
- b. Stripping of topsoil shall be restricted to those areas that are to be disturbed by construction activities such as where the soils would be likely to suffer damage associated with the engineering activities and or the installation of temporary buildings, haul routes or other areas of hardstanding. Topsoil from below any spread of trees proposed to be retained shall not be removed

- without following the guidance included within the arboricultural impact assessment.
- c. Topsoil shall not be over-stripped such that subsoil becomes incorporated, as this will reduce quality and fertility of the material.
 - d. To avoid over compaction or damage to the existing topsoil, any dedicated haul routes/access shall be stripped first with all haul distances minimised. Soil stripped from haul routes/access points will be side cast and banded local to the works and will be reinstated upon removal of the haul routes/access points.
 - e. During periods of high rainfall (>4mm/hour), topsoil stripping will be prohibited with soils allowed to dry out to mitigate any potential damage to (and degradation of) the soils.
 - f. If sustained heavy rainfall (>4 mm/hour) or surface ponding of water occurs during soil stripping operations, work shall be suspended until the ground has had at least one full dry day or agreed criteria (such as a specified moisture content) has been met. Operations shall not continue if large pools of water remain on the surface.
 - g. In order to ensure that the works are undertaken under suitable weather conditions, the timing of all soil movements shall be conditional upon approval of the environment manager/landscape specialist for the project.
 - h. The storage of stripped topsoil shall be in temporary stockpile bunds by end tipping articulated dump trucks, subsequently shaped by the use of a dozer or excavator. At the end of each shift the dozer/excavator shall seal stockpiles to prevent weather ingress by back blading. To avoid erosion and assist with stability, side batters to stockpiles shall not exceed a 1 in 2 slope.
 - i. Topsoil shall be stored in segregated bunds constructed by stripping topsoil from the storage area and using this to form a windrow around the area. Topsoil from elsewhere shall then be stored in a bund no more than 2m in height within this area to prevent any compression on the topsoil originally in the area. Following completion of the works, stored topsoil shall be taken to final place of deposition and/or re-spread at its original location.
 - j. Topsoil bunds shall be constructed where they cannot be mixed or contaminated with other soil types.
 - k. Soils from different soil types/units grading shall not be stored in the same bund.
 - l. Stripping operations shall be appropriately supervised and follow a detailed plan showing soil units to be stripped, haul routes and vehicle movements throughout the works. Information relating to the range of thickness, types and layers of soils across the route should be available so as to allow for soil units to be defined on site.
 - m. Earthmoving plant appropriate to the size of the site, the volume of soil to be stripped and the haulage distances shall be used in accordance with appropriate work practices.

- n. Tracked equipment shall be used wherever possible to reduce topsoil compaction.
 - o. Where mechanical excavators are to be used, topsoil should be stripped in accordance with the guidance and procedures set out in the defra code of practice, section 5 of bs 3882:2015 (Ref 1-2), and the ministry of agriculture fisheries and food (maff) published good practice guidance for handling soils – sheet 1: soil stripping with excavators and dump trucks (Ref 1-7).
 - p. The site shall be carefully examined for non-vegetative potentially hazardous debris (e.g. Glass, bricks, concrete) and also any invasive weeds prior to soil stripping, with any such material encountered removed. Remaining vegetation shall be cut back to approximately 300mm in height and cleared. Vegetation shall not be incorporated into topsoil to be stored.
- 3.5.2 To minimise compaction during stripping, the MAFF Guidance (Ref 1-7) recommends that the excavator should only operate on the topsoil layer and the dump trucks must only operate on the ‘basal’/non-soil layer, and the wheels must not run on to the soil layer(s). The adoption of a bed/strip system (see **Plate 2**) avoids the need for the trucks to travel on the soil layers.
- 3.5.3 Topsoil should be recovered to the full width of the strip without contamination with subsoil (not more than 20% of the lower horizon should be exposed at the layer junction within the strip). The thickness and identification of the horizon junction must be verified before and during stripping. The full thickness of the topsoil horizon should be stripped progressively along the strip before the subsoil horizons are started as shown in **Plate 2**.

Plate 2: Stripping with excavators and dump trucks: Removal of topsoil from a strip (Ref 1-7)

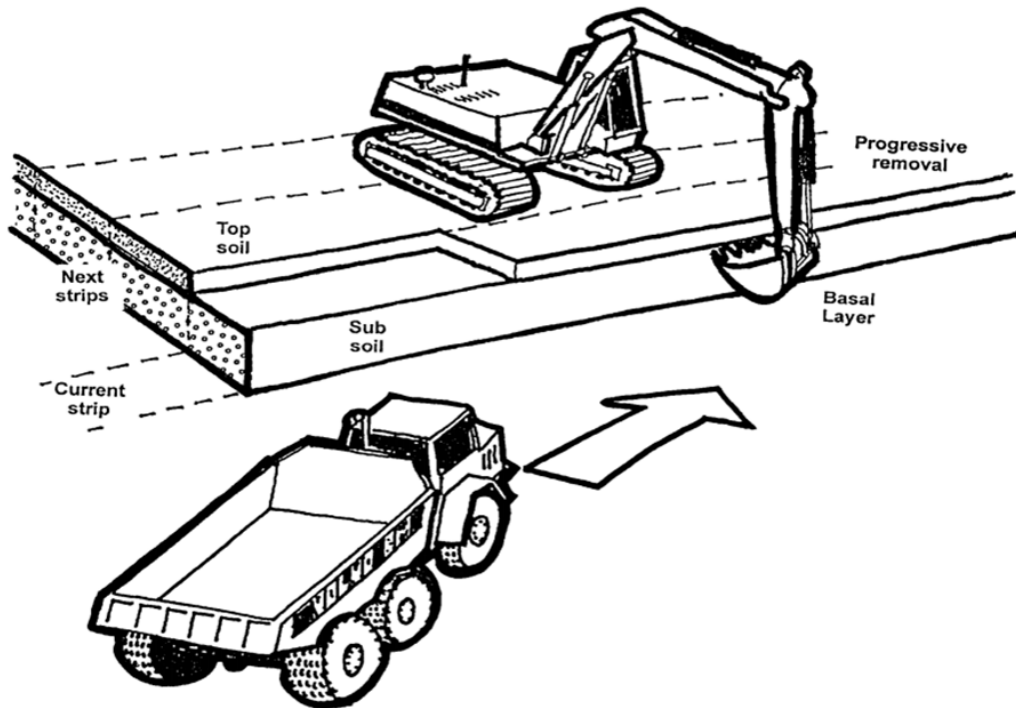

3.6 Subsoil stripping

- 3.6.1 Following topsoil stripping, the subsequent operation shall be to strip existing subsoil as required. Subsoil stripping operations shall be undertaken using similar equipment and techniques as the topsoil strip and undertaken immediately following topsoil strip operations to avoid any degradation of subsoil resources.
- 3.6.2 Subsoil stripping shall be undertaken to the depths specified on the Project earthworks plans.
- 3.6.3 The principles of the DEFRA Code of Practice (Ref 1-5) shall be applied during the stripping and handling of subsoil, in addition to the following actions:
- Any haul routes shall be run on the underlying soils and not the subsoil being stripped.
 - Subsoils of different quality and composition shall not be mixed.
 - Stockpiles of subsoil shall be segregated from topsoil to ensure that no mixing of the two soil types occurs.
- 3.6.4 Following the MAFF Guidance (Ref 1-7) to minimise compaction, the excavator should only operate on the topsoil layer and the dump trucks must only operate on the 'basal'/non-soil layer, and the wheels must not run on to the soil layer(s) as shown in **Plate 3**.

Plate 3: Stripping with excavators and dump trucks: Removal of subsoil from a strip (Ref 1-7)

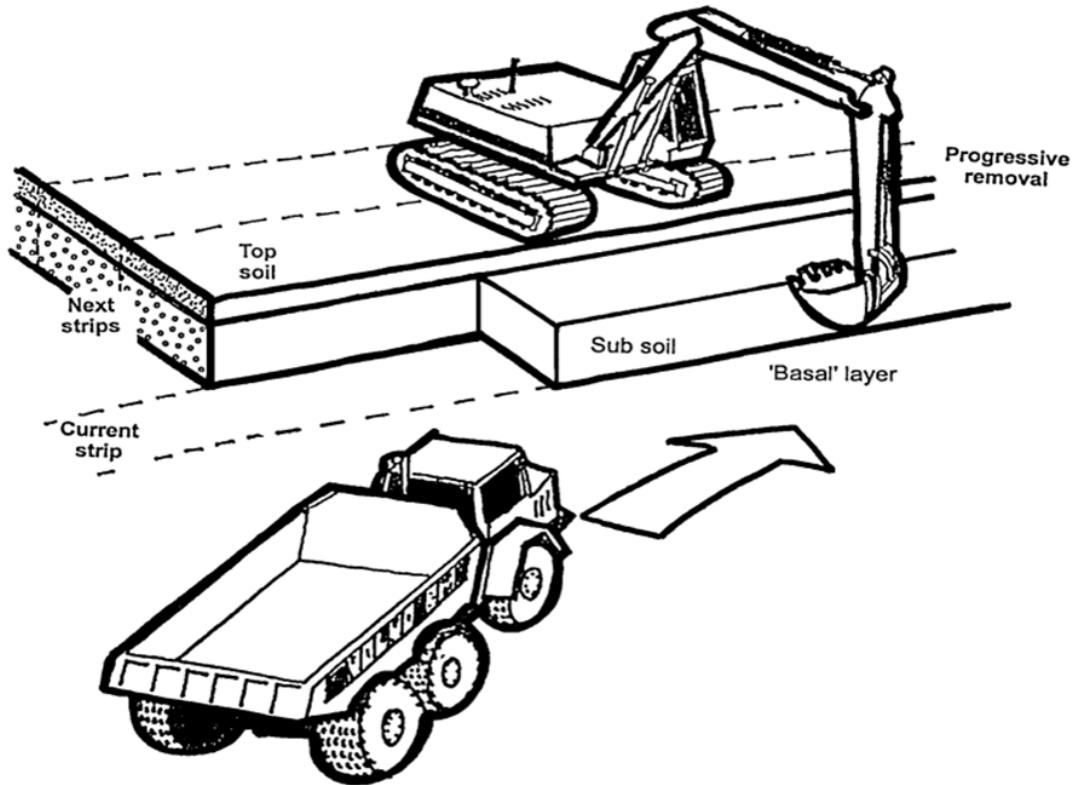

4. Soil Storage

4.1 Stockpile Construction

- 4.1.1 Following soil stripping activities, topsoil and subsoil shall be stored in separate stockpiles, the construction and design of which shall be in accordance with MAFF (Ref 1-7) published Good Practice Guide for Handling Soils – Sheet 2: Building Soil Storage Mounds with Excavators and Dump Trucks.
- 4.1.2 Reference shall also be made to the DEFRA (Ref 1-5) Code of Practice which details how stockpile size is dependent on multiple factors including the nature/ composition of the soil, the prevailing weather conditions at the time of the stripping, space limitations and any planning-related conditions or requirements attached to the consent for the Project.
- 4.1.3 The stockpile area for topsoil and subsoil will be local to the works, where it will be reused. As the quality of soil within stockpiles needs to be maintained to reduce the potential for damage to the soil's physical condition and structure, and to facilitate the re-spreading and reinstatement of soil material, stockpiles for topsoil and subsoil shall:
- a. Be carefully formed with a slope of 1 in 2, so as to reduce the potential for damage to the physical condition and future economic viability of soil resources.
 - b. Segregate topsoil and subsoil to ensure no mixture and subsequent degradation of soil quality.
 - c. Be designed to be as narrow and as low as practicable, to allow the core material to be within 1m of the surface (to prevent anaerobic conditions developing).
 - d. Be shaped in a manner that facilitates the shedding of water.
 - e. Be shaped in a manner that avoids the potential for ponding.
 - f. Be located to avoid interference with rainwater runoff from adjacent areas, and to prevent the pollution of water bodies.
 - g. Be located beyond tree canopies and identified root protection zones around trees and vegetation to be retained.
 - h. Where possible, be located in excess of 10m from any existing watercourse or drains.
- 4.1.4 When stockpiles are constructed during a period of inclement weather, stockpile cores shall be exposed and left for a minimum of one day to enable the soils to dry out prior to re-use.
- 4.1.5 Depending on the prevailing conditions, all stockpiling operations shall be undertaken in a manner consistent with either of the following methods, as detailed in the DEFRA (Ref 1-5) Code of Practice:
- a. Method 1: Dry non-plastic soils (**Plate 5**).
 - b. Method 2: Wet plastic soils (**Plate 4**).

Plate 4: Soil Stockpiling: Method 1 (Ref 1-5)

Soil stockpiling

Soil should be stored in an area of the site where it can be left undisturbed and will not interfere with site operations. Ground to be used for storing the topsoil should be cleared of vegetation and any waste arising from the development (e.g. building rubble and fill materials). Topsoil should first be stripped from any land to be used for storing subsoil.

Method 1 – Dry non-plastic soils

The soil is loose-tipped in heaps from a dump truck (a), starting at the furthest point in the storage area and working back toward the access point. When the entire storage area has been filled with heaps, a tracked machine (excavator or dozer) levels them (b) and firms the surface in order for a second layer of heaps to be tipped. This sequence is repeated (c & d) until the stockpile reaches its planned height. To help shed rainwater and prevent ponding and infiltration a tracked machine compacts and re-grades the sides and top of the stockpile (e) to form a smooth gradient.

Plate 5: Soil Stockpiling: Method 2 (Ref 1-5)

Method 2 – Wet plastic soils

The soil is tipped in a line of heaps to form a ‘windrow’, starting at the furthest point in the storage area and working back toward the access point (a). Any additional windrows are spaced sufficiently apart to allow tracked plant to gain access between them so that the soil can be heaped up to a maximum height of 2m (b). To avoid compaction, no machinery, even tracked plant, traverses the windrow.

Once the soil has dried out and is non-plastic in consistency (this usually requires several weeks of dry and windy or warm weather), the windrows are combined to form larger stockpiles, using a tracked excavator (d). The surface of the stockpile is then regraded and compacted (e) by a tracked machine (dozer or excavator) to reduce rainwater infiltration.

4.2 Management of Stockpiles

- 4.2.1 Soil stockpiles shall be placed on top of heavy-duty plastic sheeting to minimise any potential leaching of nutrients and contamination from underlying ground and construction materials. Covering of the stockpiles will be required where they are not intended for re-use within a reasonable timeframe of six months, to ensure they maintain their geophysical/geochemical characteristics and where there is risk of significant rainwater run off or creation of excessive dust.
- 4.2.2 Upon completion of formation, stockpiles shall be securely fenced off to prevent further disturbance and potential contamination by construction activities. Vehicles shall be prohibited from tracking over areas of stockpiled materials with clear visible signage in place to identify stockpile content and type e.g., topsoil or subsoil.
- 4.2.3 In order to mitigate the adverse effects of soil storage, the Site shall be managed in such a way that soil storage periods are minimised in duration. Should stockpile durations be greater than six months, the application of a mix of grass and clover seeds to the stockpile surface shall be implemented to aid in reducing potential surface erosion and prevent potential nuisance weed infestation. Any weeds that have established on the stockpiles shall be managed during summer months by the application of appropriate herbicide by spraying techniques to kill off the weeds, or by cutting techniques such as mowing and strimming to prevent any possible seed dispersion.
- 4.2.4 Within Work No.9, no temporary buildings, plant or materials will be located within the area of the fluvial floodplain or within 8m from the landward toe of the fluvial flood defence.

5. Soil Reinstatement

5.1 General

- 5.1.1 Before re-use of soil in other areas within the Project, the material will be subjected to chemical testing and will be required to meet the geochemical acceptability criteria as set out in **Appendix 21.C [TR030008/APP/6.4]** for the works. Soils being re-used within the area of excavation are not subject to the acceptability criteria.
- 5.1.2 A structured, uncompacted and well-aerated soil profile shall be formed for the successful establishment and subsequent growth of vegetation within landscape, ecological and agricultural areas.
- 5.1.3 Areas where soils are to be restored shall be protected from the in-flow of water and ponding. In locations where ponding has occurred due to inclement weather, these areas shall be drained in advance of restoration and allowed to dry out.
- 5.1.4 Prior to reinstatement, the basal layer should be profiled to a level and clean state. Reinstatement of soils shall be carried out in reverse process of the soil stripping, with the subsoil being reinstated first and the topsoil placed over the subsoil.

5.2 Subsoil

- 5.2.1 The subsoil shall be properly de-compacted to break up any panning or sealing of the ground surface, in order to reduce flood risk and to promote deeper root growth.
- 5.2.2 Dedicated haul routes shall be utilised to transport the subsoil to the first placement site and, thereafter, adherence to designated haul routes shall continue.
- 5.2.3 The spreading of subsoil shall be undertaken from the furthest point from the area access point, to avoid over compaction of already placed subsoil. Spreading shall be undertaken in uniform thickness in line with the LEMP requirements with subsequent layers applied, as required.
- 5.2.4 Should the ripping of subsoil material be deemed to be necessary, then:
 - a. The substrate material shall be thoroughly ripped to a depth of 500mm with a minimum of two passes.
 - b. Where possible, the ripper blades used shall have wide, shallow wings fixed. If this is not the case, the spacing at the surface shall be reduced.
 - c. Following ripping, the subsoil windrow shall be spread across the area using a dozer in line with the landscaping design requirements.
- 5.2.5 At the end of each day, the current strip/ segment shall be completed in full if rain is forecast. If during a day it is evident that a full strip cannot be completed, then the current segment shall be completed as a minimum.

- 5.2.6 Subsoil placement works shall be suspended if sustained heavy rainfall occurs during the soil handling operations, and not restarted until the ground has had at least a full dry day or agreed moisture content criteria can be met.
- 5.2.7 The MAFF (Ref 1-7) guidance provides a schematic illustration of the subsoil replacement with excavators and dump trucks as shown in **Plate 6**.

Plate 6: Soil Replacement with Excavators and Dump Trucks: Subsoil Layer (Ref 1-7)

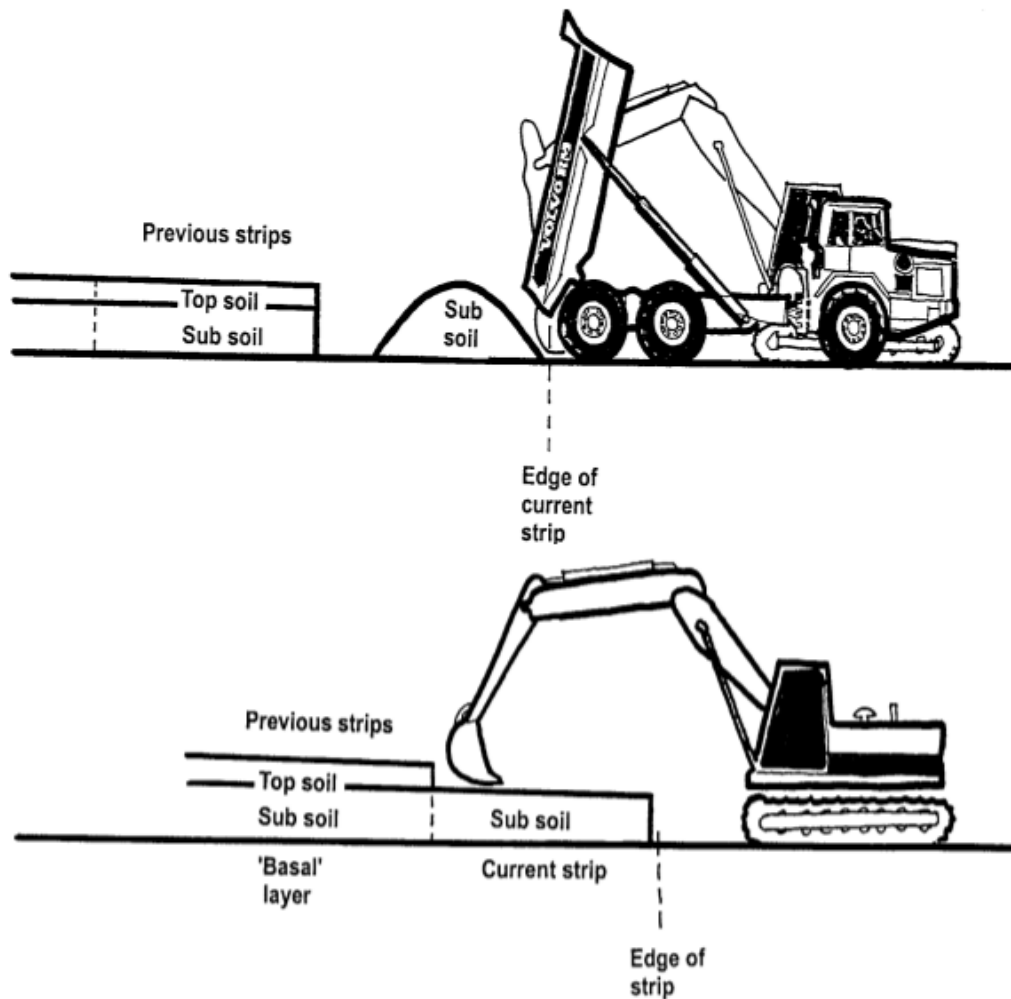

5.3 Topsoil

- 5.3.1 The application of topsoil to each designated area will be excavated from temporary storage stockpiles by 360 degree excavator, transported as required and placed in a windrow at appropriate centres from the edges of the Site and spread evenly across the Site. In spreading, the material operations shall commence at the furthest location from the access point and work backwards to avoid tracking over newly placed topsoil (see **Plate 7**).
- 5.3.2 The topsoil shall be spread to an agreed depth, generally 300 to 350mm dependant on original soil depths and the LEMP requirements, across the subsoil by dozer.

- 5.3.3 Should the ripping of topsoil be deemed to be necessary, an agricultural subsoiler with wings and narrow legs shall be used to rip the topsoil to generally 400mm dependant on soil depths, in order to remove any remaining compaction and to key into the underlying subsoil.
- 5.3.4 Topsoil placement works shall be suspended if sustained heavy rainfall occurs during the soil handling operations, and not restarted until the ground has had at least a full dry day or agreed moisture content criteria can be met.

Plate 7: Soil Replacement with Excavators and Dump Trucks: Topsoil Layer (Ref 1-7)

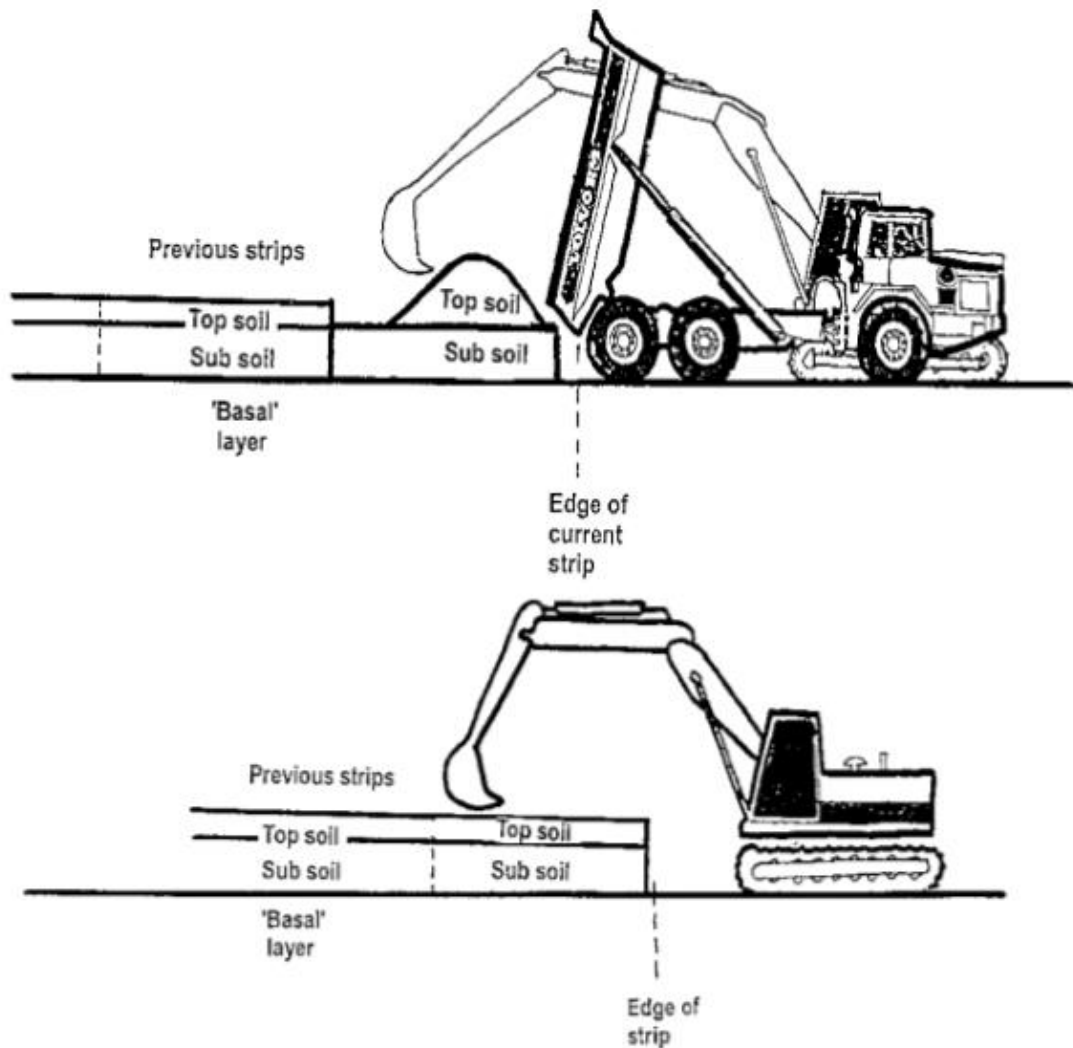

5.4 Off-Site Reuse / Disposal

- 5.4.1 It is envisaged that all soils stripped during the main works will be reused within the Project subject to the Outline Remediation Strategy. Should off-site disposal in relation to excavated soil be required, the material will be characterised to determine firstly whether it is Hazardous or Non-Hazardous waste in accordance with the Environment Agency's Technical Guidance WM3 (Ref 1-10). The

appropriate treatment or disposal facility will, where required, be determined through Waste Acceptance Criteria (“WAC”) analysis, as required.

6. References

- Ref 1-1 AECOM (2023). Immingham Ammonia Import Terminal Ground Investigation Report.
- Ref 1-2 British Standards Institution (BSI) (2015). BS 3882:2015 – Specification for Topsoil. BSI Standards Limited.
- Ref 1-3 Cranfield Soil and Agrifood Institute (2023). Soilscales.
- Ref 1-4 CL:AIRE (2011). The Definition of Waste: Development Industry Code of Practice Version 2. London: CL:AIRE.
- Ref 1-5 Department for Environment, Food and Rural Affairs (DEFRA) (2009). Construction Code of Practice for the Sustainable Use of Soils on Construction Sites. London: DEFRA.
- Ref 1-6 Highways England (2019). Design Manual for Roads and Bridges (DMRB) LA 109 Geology and Soil.
- Ref 1-7 Ministry of Agriculture Fisheries and Food (2000). Good Practice for Handling Soils. Sheet 1: Soil Stripping with Excavators and Dump Trucks. Sheet 2: Building Soil Storage Mounds with Excavators and Dump Trucks. Sheet 4: Soil Replacement with Excavators and Dump Trucks.
- Ref 1-8 Natural England (2019). Provisional Agricultural Land Classification (ALC) (England).
- Ref 1-9 Reading Agricultural Consultants (2023). Agricultural Land Classification and Soil Resources at Immingham Green Energy Terminal.
- Ref 1-10 Environment Agency (2021). Guidance on the classification and assessment of waste (1st Edition v1.2GB). Technical Guidance WM3.
- Ref 1-11 Institute of Environmental Management (IEMA). (2022). IEMA Guide: A New Perspective on Land and Soil in Environmental Impact Assessment.

Appendix C: Outline Dust Management Plan



Immingham Green Energy Terminal

TR030008

Volume 6

Appendix C – Outline Dust Management Plan

Planning Act 2008

Regulation 5(2)(a)

Infrastructure Planning (Applications: Prescribed
Forms and Procedure) Regulations 2009 (as
amended)

September 2023

Infrastructure Planning

Planning Act 2008

The Infrastructure Planning
(Applications: Prescribed Forms and
Procedure) Regulations 2009 (as amended)

Immingham Green Energy Terminal

Development Consent Order 2023

Appendix C – Outline Dust Management Plan

Regulation Reference	APFP Regulation 5(2)(a)
Planning Inspectorate Case Reference	TR030008
Application Document Reference	TR030008/APP/6.5
Author	Associated British Ports Air Products BR

Version	Date	Status of Version
Revision 1	21 September 2023	DCO Application

Table of contents

Chapter	Pages
1 Introduction	1
1.1 Brief	1
2 Location and Meteorology	2
2.1 Site Description	2
2.2 Meteorology	3
3 Control of Dust	4
3.1 Overview	4
3.2 Management Responsibility	4
3.3 Potential Dust Sources	4
3.4 Activities and Control Measures	5
4 Monitoring and Control Protocols	5
4.1 Monitoring of Meteorological Conditions	8
4.2 Visual Monitoring and Recording	8
4.3 Quantitative Monitoring	9
4.4 Dust Complaints	9
4.5 Records Management	10
5 Action Plan	11
5.1 Overview	11
5.2 Procedure	11
6 References	12

Plates

Plate 1: Five-Year Wind Rose Plot for Humberside Airport (2018 – 2022)	3
--	---

1 Introduction

1.1 Brief

- 1.1.1 This Outline Dust Management Plan (“DMP”) outlines the requirements for the control, monitoring and mitigation of airborne dust deposition associated with construction of the Project. Dust and particulate emissions generated during the construction works have the potential to:
- a. Deposit beyond the Site Boundary and affect the amenity of local sensitive receptors and the commercial viability of some land uses.
 - b. Increase the exposure of human health sensitive receptors to short-term concentrations of PM₁₀.
 - c. Smother vegetation and harm sensitive habitats.
- 1.1.2 The purpose of this Outline DMP is to provide the contractors undertaking the Project construction work with an overview of potential dust emissions sources associated with the works, the activities requiring control and the measures that are to be employed to reduce emissions and their associated impacts. The plan also identifies where responsibility needs to be assigned for specific actions.
- 1.1.3 The plan provides site management and delegated personnel with the appropriate procedures for monitoring and recording dust conditions at the Site and the actions that should be taken if and when significant levels of dust are noted beyond the Site Boundary. The control measures and actions detailed in this document are required to reduce the potential for dust emissions causing adverse effects beyond the Site Boundary to acceptable levels.
- 1.1.4 This document forms an appendix to the **Outline Construction Environmental Management Plan (“CEMP”) [TR030008/APP/6.5]**. A requirement of the draft DCO requires works to construct the Project to be in accordance with the Final CEMP, which will be produced, along with any associated management plans, prior to construction and in accordance with the outline documents submitted with the application for development consent.

2 Location and Meteorology

2.1 Site Description

- 2.1.1 The Site is located in North East Lincolnshire on the south bank of the Humber Estuary, to the east of the Port of Immingham (“the Port”), and is approximately centred on National Grid Reference (“NGR”) E520783 N415271. The land-side works fall within the administrative boundary of NELC and the Project in its entirety covers an area of approximately 121.43 ha.
- 2.1.2 The land use in the Site area is predominantly industrial in nature, being dominated by the Port, chemical manufacturing, oil processing and power generation facilities. Residential and commercial properties are present to the south of the Port, on Queens Road, and lie within and adjacent to the Site Boundary. Beyond the industrial facilities, the wider area is largely agricultural. The nearest main residential area is the town of Immingham to the west.
- 2.1.3 The nearest settlement to the Site is the town of Immingham, which is located approximately 460m west of the Site at its closest point. The closest residential and highly sensitive receptors to the Site include:
- Ten residential properties located on the west side of Queens Road (1-6 and 31 Queens Road with upper floor flats at 7-8 and 18) which are included within the Site Boundary. These properties have been included within the Site Boundary as their continued residential use is not considered compatible with the operation of the Project. However, they may still be occupied during the construction phase of the Project and sensitive to construction dust emissions.
 - Residential properties on the eastern edge of the Immingham urban area, including Somerton Road, Worsley Road, Dunster Walk, Ings Lane, Oakham Walk, Kendal Road, Chestnut Avenue, Waterworks Street and Spring Street, which at the closest point are located between approximately 460m and 480m west of the West Site.
 - Mauxhall Farm off Stallingborough Road, located approximately 1km south-west of the West Site.
- 2.1.4 Non-residential land uses that are also sensitive receptors to construction dust impacts include:
- Some of the commercial land uses on Queens Road.
 - Neighbouring energy generating plant sites and specifically their air intakes.
 - Public Rights of Way.
- 2.1.5 Nearby nature conservation sites include.
- Humber Estuary European Marine Site (“EMS”).
 - A Local Wildlife Site at Laporte Road and adjacent to the ‘East Site’.

2.2 Meteorology

2.2.1 **Plate 1** displays a wind rose plot of five years of hourly sequential meteorological data from Humberside Airport.

2.2.2 The plot demonstrates the high propensity for winds to blow from the southwest and the limited tendency for winds to blow from any other direction, particularly from the northwest and southeast.

2.2.3 With these meteorological conditions in mind, winds will often blow across the 'East Site' out onto the Estuary, blow across the pipeline corridor and towards land uses off Laporte Road, and blow across the 'West Site' towards land uses off Queens Road.

Plate 1: Five-Year Wind Rose Plot for Humberside Airport (2018 – 2022)

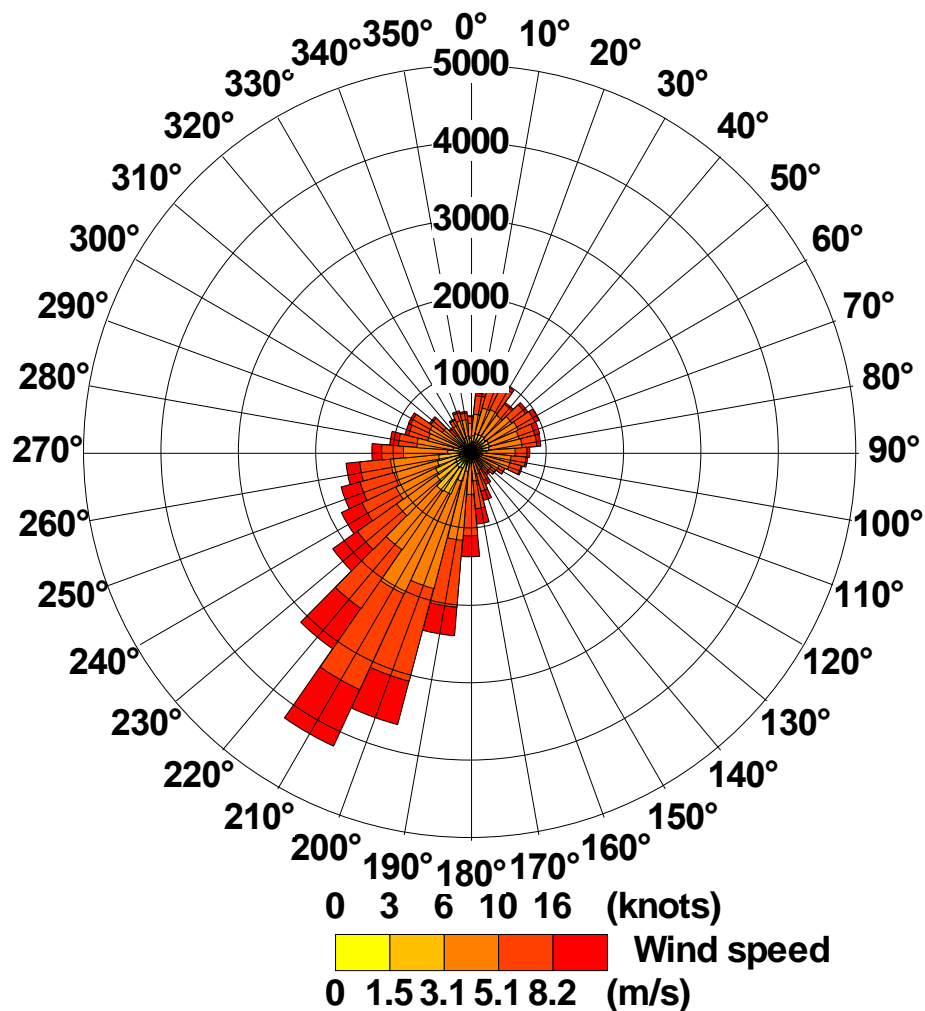

3 Control of Dust

3.1 Overview

- 3.1.1 The aims of the dust control measures set out within this plan are consistent with the key planning principles described in relevant national and local planning policy, and guidance documents released by the Institute of Air Quality Management (Ref 1-1) and the Building Research Institute (Ref 1-2). Specifically, that dust emissions should, as far as possible, be controlled, mitigated or removed at source. These documents provide guidance to assist with the control of dust and fine particulate matter emissions associated with construction and demolition activities.
- 3.1.2 The objective of this plan is to minimise the visible release of airborne dusts and particulates arising from all construction works, including earthworks, construction activities, the movement of vehicles on and off site, and the storage and handling of dusty materials, and to prevent releases in such quantities or concentrations that are likely to cause pollution of the environment, harm human health and or bring about serious detriment to the amenity of the locality.

3.2 Management Responsibility

- 3.2.1 The Site Manager is the designated individual with the responsibility for ensuring that the Dust Management Plan is enforced on site, and that its contents are communicated to all employees and contractors working at the site as part of the site induction procedure.
- 3.2.2 Should an off-site complaint be received about fugitive dust emissions, it is the Site Manager's responsibility that an investigation into the cause is undertaken and to ensure corrective action is applied where necessary, in line with the Action Plan outlined in **Section 5** of this document.
- 3.2.3 The Site Manager will also be the designated point of contact for local residents who may be concerned about dust emissions. The contact details for the Site Manager will be supplied to the Environmental Health Officer prior to works commencing on site.

3.3 Potential Dust Sources

- 3.3.1 The site activities required during the construction of the Project have the potential to generate dust emissions that could impact beyond the Site Boundary, without the application of the appropriate mitigation listed in **Section 3.4** of this Dust Management Plan ("DMP").
- 3.3.2 Potential dust sources include:
- Enabling works and the removal of any existing infrastructure.
 - Earthworks associated with the levelling of ground and the burying of services.
 - The storage and handling of dust generating materials, such as soil, sand and hardcore.
 - On site concrete batching.

- e. The erection of Project buildings and structures, depending on the construction materials.
- f. The movement of construction vehicles on site, on paved and unpaved surfaces.
- g. The movement of construction vehicles of site and on the public road network.
- h. Landscaping works.

3.3.3 In line with the Institute of Air Quality Management guidance (Ref 1-1), a risk assessment of potential dust emissions impacts has been undertaken to identify the level of mitigation required to control the risk of offsite dust impact, as reported in **Chapter 6: Air Quality [TR030008/APP/6.2]**.

3.4 Activities and Control Measures

3.4.1 The following describes the activities and control measures that would be applied at all times during all phases of work and operations at the Site.

- a. Develop and implement a stakeholder communications plan that includes community engagement before work commences on site.
- b. Display the name and contact details of person(s) accountable for air quality and dust issues on the site boundary. This may be the environment manager/engineer or the site manager.
- c. Display the head or regional office contact information.
- d. Develop and implement a Dust Management Plan (“DMP”), which may include measures to control other emissions, approved by the Local Authority. The level of detail will depend on the risk, and should include as a minimum the measures set out here and within the **Outline CEMP [TR030008/APP/6.5]**. The DMP may include monitoring of dust deposition, dust flux, real-time PM₁₀ continuous monitoring and/or visual inspections, as required for the risk associated with the site.
- e. Record all dust and air quality complaints, identify cause(s), take appropriate measures to reduce emissions in a timely manner, and record the measures taken.
- f. Make the complaints log available to the local authority when asked.
- g. Record any exceptional incidents that cause dust and/or air emissions, either on- or off-site, and the action taken to resolve the situation in the log book.
- h. Hold regular liaison meetings with other construction sites within 500m of the site boundary, to ensure plans are co-ordinated and dust and particulate matter emissions are minimised. It is important to understand the interactions of the off-site transport/deliveries which might be using the same strategic road network routes.
- i. Undertake daily on-site and off-site inspection, where receptors (including roads) are nearby, to monitor dust, record inspection results, and make the log available to the local authority when asked. This would include regular dust soiling checks of surfaces such as street furniture, cars and window sills within 100m of site boundary, with cleaning to be provided if necessary.

- j. Carry out regular site inspections to monitor compliance with the DMP, record inspection results, and make an inspection log available to the local authority when asked.
- k. Increase the frequency of site inspections by the person accountable for air quality and dust issues on site when activities with a high potential to produce dust are being carried out and during prolonged dry or windy conditions.
- l. Agree dust deposition, dust flux, or real-time PM₁₀ continuous monitoring locations with the Local Authority. Where possible commence baseline monitoring at least three months before work commences on site or, if it is a large site, before work on a phase commences. Further guidance is provided by IAQM on monitoring during earthworks and construction.
- m. Plan site layout so that machinery and dust causing activities are located away from receptors, as far as is possible.
- n. Erect solid screens or barriers around dusty activities or the Site Boundary that are at least as high as any stockpiles on site.
- o. Fully enclose site or specific operations where there is a high potential for dust production and the site is active for an extensive period.
- p. Avoid site runoff of water or mud.
- q. Keep site fencing, barriers and scaffolding clean using wet methods.
- r. Remove materials that have a potential to produce dust from the Site as soon as possible, unless being re-used on site. If they are being re-used on-site cover as described below.
- s. Cover, seed or fence stockpiles to prevent wind whipping.
- t. Ensure all on-road vehicles comply with the requirements of relevant NRMM standards, where applicable.
- u. Ensure all vehicles switch off engines when stationary - no idling vehicles.
- v. Avoid the use of diesel or petrol powered generators and use mains electricity or battery powered equipment where practicable.
- w. Impose and signpost a maximum-speed-limit of 15mph on surfaced and 10 mph on unsurfaced haul roads and work areas (if long haul routes are required these speeds may be increased with suitable additional control measures provided, subject to the approval of the nominated undertaker and with the agreement of the local authority, where appropriate).
- x. Produce a CTMP based on the **Outline CTMP [TR030008/APP/6.7]** to manage the sustainable delivery of goods and materials;
- y. Implement a Construction Worker Travel Plan (“CWTP”) based on the **Outline CWTP [TR030008/APP/6.7]** that supports and encourages sustainable travel (public transport, cycling, walking, provision of multi-occupancy vehicles and car-sharing).
- z. Only use cutting, grinding or sawing equipment fitted or in conjunction with suitable dust suppression techniques such as water sprays or local extraction, e.g. suitable local exhaust ventilation systems.

- aa. Ensure an adequate water supply on the site for effective dust/particulate matter suppression/mitigation, using non-potable water where possible and appropriate.
- bb. Use enclosed chutes and conveyors and covered skips.
- cc. Minimise drop heights from conveyors, loading shovels, hoppers and other loading or handling equipment and use fine water sprays on such equipment wherever appropriate.
- dd. Ensure equipment is readily available on site to clean any dry spillages, and clean up spillages as soon as reasonably practicable after the event using wet cleaning methods.
- ee. Avoid bonfires and burning of waste materials.
- ff. Avoid scabbling (roughening of concrete surfaces) if possible.
- gg. Ensure sand and other aggregates are stored in bunded areas and are not allowed to dry out, unless this is required for a particular process, in which case ensure that appropriate additional control measures are in place.
- hh. Ensure bulk cement and other fine powder materials are delivered in enclosed tankers and stored in silos with suitable emission control systems to prevent escape of material and overfilling during delivery.
 - ii. For smaller supplies of fine power materials ensure bags are sealed after use and stored appropriately to prevent dust.
- jj. Use water-assisted dust sweeper(s) on the access and local roads, to remove, as necessary, any material tracked out of the site. This may require the sweeper being continuously in use.
- kk. Avoid dry sweeping of large areas.
- ll. Ensure vehicles entering and leaving sites are covered to prevent escape of materials during transport;
- mm. Inspect on-site haul routes for integrity and instigate necessary repairs to the surface as soon as reasonably practicable.
- nn. Implement a wheel washing system (with rumble grids to dislodge accumulated dust and mud prior to leaving the site where reasonably practicable).
- oo. Ensure there is an adequate area of hard surfaced road between the wheel wash facility and the site exit, wherever site size and layout permits.
- pp. Access gates to be located at least 10 m from receptors where possible.

4 Monitoring and Control Protocols

4.1 Monitoring of Meteorological Conditions

4.1.1 The Site Manager or suitable delegate will be required to consider the likelihood of adverse weather conditions, such as long dry spells and periods of strong wind, by accessing an appropriate source of weather forecast data. This allows appropriate preventative action to be taken during times when there is the risk that site operations will give rise to significant dust emissions. Alternatively, activities with the potential to generate significant amounts of dust will be postponed, if necessary, until there are more favourable weather conditions.

4.1.2 A record of the meteorological conditions during each day of operations at the site should be maintained, to assist in the substantiation of complaints or to inform the results of visual and quantitative monitoring (if required). This should include the following information:

- a. Date.
- b. Description of conditions in AM and PM (sunny, dry, cloudy, wet, windy, etc).
- c. Predominant wind direction in AM and PM.
- d. Wind speed in AM and PM.

4.1.3 Some of the data described above can be obtained from online meteorological resources, such as the BBC, the Met Office and metcheck websites.

4.2 Visual Monitoring and Recording

4.2.1 It will be the responsibility of all site personnel to maintain a visual awareness of dust emissions during the working day. Any significant dust emission occurring with the potential to travel beyond the Site Boundary will be reported to the Site Manager, who will be responsible for investigating the cause and taking immediate action to minimise further emissions. If necessary, site operations will be halted until an appropriate remedial action can be implemented.

4.2.2 A regular inspection of the Site Boundary will be made, by the Site Manager or another designated individual, to check for abnormal levels of dust deposition. If abnormal levels are found, the Site Manager or other designated individual will investigate the cause. Immediate remedial action will be taken where necessary.

4.2.3 A record of all visual monitoring will be kept for each day of operation. This will include the following information:

- a. Date and time.
- b. Summary of meteorological conditions.
- c. Whether or not evidence of dust deposition is found.
- d. If so, where and to what extent.
- e. A summary of the operational activities undertaken that day.
- f. A description of the remedial actions taken and changes made to operational procedures, in order to eliminate or minimise dust emissions.
- g. Details of any complaints received.

4.3 Quantitative Monitoring

- 4.3.1 It is not anticipated that quantitative monitoring will be required during the works. However, should the regular visual inspections identify that significant quantities of dust have traversed the Site Boundary, and or if there are regular substantiated complaints, then quantitative monitoring will be required.
- 4.3.2 The quantitative monitoring of particulate matter concentrations would then be carried out on-site to consolidate the Site Manager's awareness of on-site dust conditions and information obtained from visual inspections and staff reports. The quantitative monitoring would not be intended to replace the need for a day-to-day visual inspection regime but would instead be a supplemental source of information that can be used to confirm that the dust control measures in place at the site are effective in controlling emissions across the Site Boundary. In the event of an off-site complaint being received, monitoring data could be referred to as an additional source of information during the investigation process.
- 4.3.3 The method of monitoring would be agreed as part of the final plan with NELC but would likely include a combination of passive data collection, by the use of sticky-pad dust gauges, and real-time data collection, by the use of a handheld electronic dust monitoring device.

4.4 Dust Complaints

- 4.4.1 The contact telephone number for the Site shall be permanently displayed at the Site entrance, to make the process as straight-forward as possible for members of the public.
- 4.4.2 Should a site dust related complaint be received either directly or via the Environmental Health Officer/Planning Authority, then this shall be investigated within one working day and where necessary, measures to reduce the problem shall be implemented in accordance with the Action Plan outlined in **Section 5**.
- 4.4.3 All dust related complaints shall be logged within a specific complaint register, details to include:
- a. The date and time that the complaint was received by the Site.
 - b. The nature of the complaint.
 - c. Location of where the subject of the complaint occurred.
 - d. Meteorological conditions at the time of the subject of the complaint.
 - e. The name, address and telephone number of the complainant.
 - f. Whether or not the complaint is substantiated (i.e. reference to the Visual Dust Monitoring record).
 - g. Remedial action undertaken during the resulting investigation.
- 4.4.4 The complaint register shall be kept on site and be made available for inspection by the Environmental Health Officer at NELC during normal site operating hours.
- 4.4.5 In the case of serious or persistent complaints the need for fully independent professional advice will be considered.

4.4.6 Problems concerning dust from site activities can sometimes be avoided by taking a considerate and neighbourly approach to relations with the local residents. For example, if works outside of normal working hours is required, then the residents and NELC will be notified accordingly.

4.5 Records Management

4.5.1 The Site Manager will ensure that records required by the DMP are completed and retained. These include:

- a. Daily site inspection records.
- b. Details of all dust emissions incidents, including the date, time, source and any remedial action undertaken.
- c. Details of complaints, investigations and remedial action as outlined above.
- d. Details of site routine monitoring (e.g. weather conditions) and additional quantitative monitoring.

5 Action Plan

5.1 Overview

- 5.1.1 If significant levels of dust, i.e. those which are considered likely to cause harm to amenity, damage to property, or a health hazard, are noted during routine site inspections and visual assessments, the actions detailed within this section will be taken immediately.
- 5.1.2 The actions detailed below will also be implemented if an off-site complaint is received regarding fugitive emissions of dust across the Site Boundary. If the implementation of any part of this Action Plan was triggered by an off-site complaint, the outcome shall be communicated to NELC and the Environmental Health Officer by email within 2 working days.

5.2 Procedure

- 5.2.1 Should significant levels of dust be identified, the following actions will be implemented:
- a. Identify and establish the process and operations responsible for the abnormal emissions by review of the complaint and reference to weather forecast data for the time of the incident.
 - b. Cease the process and operations responsible until corrective action can be taken, or adverse weather conditions change.
 - c. Implement corrective action, such as the use of water sprays to dampen down surfaces, or the temporary relocation of a work activity until the wind direction or other adverse weather conditions change.
 - d. Enter a full record of the findings of the investigation and the actions taken within site log book.
 - e. Notify the Environmental Health Officer if required.
 - f. Review and update the DMP and site practices where any new measures are required in light of the incident.

6 References

- Ref 1-1 Holman et al (2014). IAQM Guidance on the assessment of dust from demolition and construction, Institute of Air Quality Management, London.
- Ref 1-2 V Kukadia, S Upton, D Hall (2003). Control of dust from construction and demolition activities - Building Research Establishment.

Appendix D: Outline Reptile Precautionary Working Method Statement



Immingham Green Energy Terminal

TR030008

Volume 6

Appendix D – Outline Reptile Precautionary Working
Method Statement

Planning Act 2008

Regulation 5(2)(a)

Infrastructure Planning (Applications: Prescribed
Forms and Procedure) Regulations 2009 (as
amended)

September 2023

Infrastructure Planning

Planning Act 2008

The Infrastructure Planning
(Applications: Prescribed Forms and
Procedure) Regulations 2009 (as amended)

Immingham Green Energy Terminal Development Consent Order 2023

Appendix D – Outline Reptile PWMS

Regulation Reference	APFP Regulation 5(2)(a)
Planning Inspectorate Case Reference	TR030008
Application Document Reference	TR030008/APP/6.5
Author	Associated British Ports Air Products BR

Version	Date	Status of Version
Revision 1	21 September 2023	DCO Application

Table of contents

1	Introduction	1
1.1	Background and Scope	1
1.2	Legislation	1
1.3	Precautionary Working Method Statement.....	2
1.4	References.....	4

1 Introduction

1.1 Background and Scope

- 1.1.1 This Outline Reptile Precautionary Working Method Statement (“PWMS”) (**Table 1**) sets out the proposed procedures and practises to be implemented during the construction works for the Project to address the low risk of encountering reptiles during construction.
- 1.1.2 This PWMS relates only to works undertaken on Ditch 5 (**Work No. 1**) as this is the only ditch impacted by the Project that was identified as having some limited potential to support grass snake (*Natrix helvetica*).
- 1.1.3 No specific reptile surveys were undertaken for the Project due to the general low suitability of habitat affected, and the low risk of reptiles being present. This risk was evaluated in **Appendix 8.B: Preliminary Ecological Appraisal Report** of the Environmental Statement [TR030008/APP/6.4], where it was identified that appropriate precautionary working methods would be sufficient to address any low residual risk of grass snake being present on Ditch 5.

1.2 Legislation

- 1.2.1 Common species of reptile (which includes grass snake) are protected against intentional killing and injury under Schedule 5 of the *Wildlife and Countryside Act 1981* (as amended). There is no requirement for a licence where development works affect common species of reptiles. Instead, Natural England advise (Ref 1-1) that where reptiles are present, they should be protected from any harm that might arise during the development works through appropriate mitigation.

1.3 Precautionary Working Method Statement

Table 1: Draft Reptile Precautionary Working Method Statement

Reptiles: Draft Precautionary Working Method Statement		
Action	Rationale	Responsibility
<p>Toolbox Talk</p> <p>All site personnel would be briefed as to the legislative protection afforded to reptiles at a toolbox talk prior to commencing works.</p> <p>All site personnel would sign a Toolbox Talk attendance sheet prior to commencing works.</p>	Awareness	Contractor
<p>Pre-construction Ecology Walkover</p> <p>If works are being undertaken in the period February to November (inclusive), a pre-construction walkover would be undertaken by an ecologist to ensure that no reptiles are present in the working area.</p> <p>If a reptile is encountered, works would be temporarily suspended until it has been moved to a place of safety by a suitably qualified ecologist.</p>	Avoidance of accidental killing/ injury	Contractor's appointed Ecologist
<p>Sensitive Vegetation Clearance</p> <p>If works are being undertaken in the period February to November (inclusive), a staged strim of vegetation would be undertaken under ecological supervision to encourage reptiles to vacate the area.</p>	Avoidance of accidental killing/ injury	Contractor's appointed Ecologist
<p>Reptile Discovery</p> <p>In the event of a reptile discovery, work would stop temporarily, and an ecologist would be contacted for advice.</p> <p>Works can re-commence once the reptile has been moved to a place of safety away from construction activities.</p>	Avoidance of accidental killing/ injury	Contractor
<p>Review of PWMS</p>	Avoidance of accidental killing/ injury	Client

Reptiles: Draft Precautionary Working Method Statement		
Action	Rationale	Responsibility
If reptiles are encountered, a review of working practices may be required to further reduce the risks of encountering reptiles.		

1.4 References

Ref 1-1 English Nature (2004) Reptiles: guidelines for developers.

Appendix E: Outline Asbestos Management Plan



Immingham Green Energy Terminal

TR030008

Volume 6

Appendix E – Outline Asbestos Management Plan

Planning Act 2008

Regulation 5(2)(a)

Infrastructure Planning (Applications: Prescribed
Forms and Procedure) Regulations 2009 (as
amended)

September 2023

Infrastructure Planning

Planning Act 2008

The Infrastructure Planning
(Applications: Prescribed Forms and
Procedure) Regulations 2009 (as amended)

Immingham Green Energy Terminal Development Consent Order 2023

Appendix E – Outline Asbestos Management Plan

Regulation Reference	APFP Regulation 5(2)(a)
Planning Inspectorate Case Reference	TR030008
Application Document Reference	TR030008/APP/6.5
Author	Associated British Ports Air Products BR

Version	Date	Status of Version
Revision 1	21 September 2023	DCO Application

Table of contents

1	Introduction	1
1.1	Background and Scope	1
1.2	Purpose of Asbestos Management Plan	1
1.3	Proposed Works.....	2
1.4	Reference and Guidance Documents	2
1.5	Document Control	3
1.6	Relationship to Other Management Plans.....	3
2	Duty Holder and Responsibilities	4
2.1	Duty Holder	4
2.2	Responsibilities	4
3	Asbestos Identification and Risk Assessment.....	6
3.1	Risk Assessment.....	6
3.2	Asbestos in the Ground.....	6
3.3	Licensable and Notifiable Work.....	6
4	Asbestos Work Procedures	9
4.1	General	9
4.2	Plan of Work	9
4.3	Asbestos Management Procedures	10
5	Asbestos Working Requirements.....	14
5.1	Training Requirements.....	14
6	References.....	15

Plates

Plate 1:	Non-Licensed Works Decision Flow Chart	8
Plate 2:	Procedure of Uncovering Suspected Asbestos Materials and Emergencies	13

1 Introduction

1.1 Background and Scope

1.1.1 This Outline Asbestos Management Plan sets out the proposed procedures and practises to be implemented during the construction works for the Project to ensure any asbestos encountered during the works will be properly managed and the associated impacts adequately mitigated. The Project comprises the following distinct areas:

- a. Terminal comprising a jetty and topside infrastructure.
- b. A corridor Jetty Access Corridor between the jetty and Laporte Road to support a jetty access road, the ammonia import pipeline to the East Site (and a reserved corridor for future pipelines including CO₂).
- c. East Site on which the ammonia storage and hydrogen production would be undertaken.
- d. Pipeline Corridor between the East and West Sites for the transfer of ammonia, hydrogen, nitrogen and utilities.
- e. West Site, where hydrogen production, hydrogen liquefaction, storage and loading would be undertaken.
- f. Pipeline Corridor between the East and West Sites for the transfer of ammonia, hydrogen, nitrogen and utilities.
- g. Temporary Construction Areas for laydown and construction compounds.
- h. Four areas on Kings road to enable the Temporary modification of overhead cables and temporary remove of signage, lampposts and street furniture on Kings Road.

1.1.2 The Site is located on the south bank of the Humber Estuary and to the east of the Port of Immingham (“the Port”) in North East Lincolnshire. The Site covers an area of approximately 121.43 ha.

1.1.3 A Site Location Plan is included within the Application (**Figure 1.1 [TR030008/APP/6.3]**).

1.2 Purpose of Asbestos Management Plan

1.1.1 This Outline Asbestos Management Plan (“AMP”) details the measures that will be implemented onsite to ensure any asbestos encountered during the works will be properly managed and the associated impacts adequately mitigated. This is in line with the requirements of the Outline Construction Environmental Management Plan (“CEMP”) and **Chapter 21: Ground Conditions and Land Quality** of the Environmental Statement (“ES”) **[TR030008/APP/6.2]**.

1.1.2 The purpose of this document is to set out the following:

- a. Appraisal of the identified and likely locations of Asbestos Containing Materials (“ACM”).

- b. Watching brief for ACM identification.
- c. Protocol for inspecting arisings, initial visual identification of ACM, follow up verification testing.
- d. Stockpiling of arisings: protocol, coverage and safeguarding.
- e. Protocol for ACM removal where necessary.

1.3 Proposed Works

1.1.3 Subject to the DCO being granted, there would be a phased approach to the construction of the Project. The construction is likely to commence in early 2025.

1.1.4 The anticipated timeline of phases during the works are summarised in **Table 1**;, which has been included from the CEMP (**Appendix 2.C of Chapter 2: The Project**).

Table 1: Indicative Construction Phasing Timeline for Associated Development

Phase	Year 1	Year 2	Year 3	Year 4	Year 5	Year 6	Year 7	Year 8	Year 9	Year 10	Year 11
Phase 1											
Phase 2											
Phase 3											
Phase 4											
Phase 5											
Phase 6											

Source: Chapter 2 – The Project, Appendix 2.C – Outline Construction Environmental Management Plan

1.1.5 The start of construction of Phase 2 (here shown in Year 4), will depend on a number of factors including market demands for hydrogen at that point in time and the timing of subsequent phases would be subject to the same tests. Construction of Phases 2 – 6 may take up to eight years if built consecutively.

1.1.6 Further detailed information on the construction programme can be found in the Outline Construction Environmental Management Plan **[TR030008/APP/6.2]**.

1.4 Reference and Guidance Documents

1.1.7 This document has been prepared in accordance with the provisions of the Control of Asbestos Regulations (“CAR”) (Ref 1-13) and the guidance provided in the CL:AIRE, Control of Asbestos Regulations 2012 - Interpretation for Managing and Working with Asbestos in Soil and Construction and Demolition Materials: Industry guidance (Ref 1-3). Other documents consulted are listed here:

- a. AECOM. (June 2023). Immingham Ammonia Import Terminal. Ground Investigation Report. Air Products PLC. Report Reference 60687114 (Ref 1-2).
- b. Geotechnical Engineering Limited (May 2023). AP Ammonia Import Terminal Factual Ground Investigation Report. Report Reference 37312 (Ref 1-4).
- c. AECOM (February 2022). Immingham NH3 Project Development Appraisal Report. Document 60673509-GTN-DAR-001 Revision 00 (Ref 1-1).
- d. Construction (Design and Management) Regulations 2015 (Ref 1-11).
- e. Environmental Protection Act 1990 (Ref 1-10).
- f. Health and Safety at Work Act 1974 (Ref 1-5).
- g. HSE (2012), Asbestos Essentials – Advice on non-licensed work with asbestos (Ref 1-6).
- h. HSE (2012), Asbestos: The Licensed Contractors’ guide HSG247 (Ref 1-7).
- i. HSE (2013) Managing and working with asbestos. Control of Asbestos Regulations 2012 – Approved code of practice and guidance (Ref 1-8).
- j. HSE (2017) Asbestos health and safety. (Ref 1-9).
- k. The Environmental Protection (Duty of Care) Regulations 1991 (Ref 1-12).
- l. The Hazardous Waste (England and Wales) (Amendment) Regulations 2016 (Ref 1-14).

1.5 Document Control

- 1.1.8 This Outline Asbestos Management Plan will be a ‘live’ document, which will be kept under continuous review by the Principal Contractor (“PC”). This will ensure that any additional information relating to asbestos obtained during the works, detailed design and any lessons learned on the proposed development are taken into account. It will also allow for the inclusion of any further conditions and amendments that arise from the granting of any temporary works environmental permits/licences/consents, a review of environmental monitoring results or the legitimate concerns of Third Parties.

1.6 Relationship to Other Management Plans

- 1.1.9 An Outline CEMP has been developed and submitted as part of the application for development consent, this Outline Asbestos Management Plan forms an appendix to the Outline CEMP. The Outline CEMP will be reviewed, revised and updated to Final CEMP(s), along with any associated management plans, prior to construction as per Requirement 6 of the draft DCO.
- 1.1.10 This Outline AMP will form part of the Outline CEMP and the strategy set out in this document where applicable will comply with the requirements of the following management plans:
- a. Outline Remediation Strategy (**Appendix 21.C [TR030008/APP/6.4]**)

2 Duty Holder and Responsibilities

2.1 Duty Holder

2.1.1 The duty to manage asbestos is contained in Regulation 4 of the CAR 2012 (Ref 1-13). The duty holder is regarded as the owner of the non-domestic premises or the person or organisation that has clear responsibility for the maintenance or repair of non-domestic premises.

2.1.2 The duty holder is responsible for ensuring that appropriate preventive and control measures are implemented and maintained. Employees and workers must also be committed to working in accordance with the policies and measures provided by the duty holder.

2.2 Responsibilities

2.2.1 The CAR 2012 (Ref 1-13) requires the duty holder to:

- a. Take reasonable steps to find out if there are materials containing asbestos in non-domestic premises, and if so, its amount, where it is and what condition it is in.
- b. Presume materials contain asbestos unless there is strong evidence that they do not.
- c. Make, and keep up-to-date, a record of the location and condition of the asbestos- containing materials - or materials which are presumed to contain asbestos.
- d. Assess the risk of anyone being exposed to fibres from the materials identified.
- e. Prepare a plan that sets out in detail how the risks from these materials will be managed.
- f. Take the necessary steps to put the plan into action.
- g. Periodically review and monitor the plan and the arrangements to act on it so that the plan remains relevant and up-to-date.
- h. Provide information on the location and condition of the materials to anyone who is liable to work on or disturb them.

2.2.2 All site workers and personnel have responsibility to:

- a. Take reasonable care for their own health and safety.
- b. Take reasonable care that their acts or omissions do not adversely affect the health and safety of other persons.
- c. Comply with instructions given for their own safety and health and that of others generally.
- d. Comply with all work procedures and instructions related to asbestos.
- e. Co-operate with supervisors and managers in their fulfilment of legislative obligations.

- f. Report immediately to their supervisor any perceived safety or health risk.
- g. Wear and maintain in good order all protective clothing and apparatus provided by the manager or supervisor for personal protection and maintain same in good order.
- h. Ensure all equipment is in good working order.

2.2.3 Visitors at the site have a responsibility in relation to asbestos to:

- a. Comply with instructions given for their own safety and health and that of others generally.
- b. Comply with all work procedures and instructions related to asbestos.
- c. Co-operate with the duty holder or site manager in their fulfilment of legislative obligations.
- d. Take care of their safety and health and that of others.
- e. Report immediately to the site manager any perceived safety or health risk.

3 Asbestos Identification and Risk Assessment

3.1 Risk Assessment

3.1.1 The risk to human health from asbestos is related to the inhalation and ingestion of asbestos fibres. Therefore, any asbestos cement fragments or friable material present a negligible risk if placed or present beneath a non-ACM bearing soil layer and undisturbed. Friable asbestos may generate elevated airborne fibre levels if lying on the surface or disturbed and cement fragments may also do so if they are broken up and pulverised such as may occur during planned construction works at the site.

3.1.2 During the works for the Project, the receptors at risk of asbestos exposure includes construction workers, supervisors, visitors and residents and users of nearby properties.

3.2 Asbestos in the Ground

3.2.1 During the recent ground investigation (“GI”) (Ref 1-2) thirty samples were analysed for the presence of asbestos. Two samples within the East Site, E-BH10 (East Site Ammonia Storage Area) and E-BH25 (East Site Hydrogen Production Area) identified asbestos to be present in the form of chrysotile. The asbestos was identified at ground level within the Made Ground deposits. The sample within E-BH25 was described by the laboratory as loose fibres and the sample in E-BH10 was quantified with a mass of <0.001 %.

3.2.2 Based on the information from the ground investigation as summarised above, it is considered that there is a low risk of exposure to asbestos in the ground during the preliminary works at the site.

3.3 Licensable and Notifiable Work

3.3.1 The CAR 2012 (Ref 1-13) specifies three categories of work with asbestos containing materials. These are:

- a. Licensable work,
- b. Non-licensable work,
- c. Notifiable non-licensable work.

3.3.2 Licensable work with asbestos is work where:

- a. The exposure to asbestos of employees is not sporadic and of low intensity.
- b. In relation to which the risk assessment cannot clearly demonstrate that the control limit will not be exceeded.
- c. On asbestos coating.
- d. On asbestos insulating board or asbestos insulation for which the risk assessment:
 - i. Demonstrates that the work is not sporadic and of low intensity.

ii. Cannot clearly demonstrate that the control limit will not be exceeded.

iii. Demonstrates that the work is not short duration work;

3.3.3 Non-licensable work with asbestos is work where:

a. The exposure to asbestos of employees is sporadic and of low intensity.

b. It is clear from risk assessment that the exposure to asbestos of any employee will not exceed the control limit.

c. The work falls into one of the following categories:

i. Short, non-continuous maintenance tasks with only non-friable materials.

ii. Removal without deterioration of non-degraded materials in which the asbestos fibres are firmly linked in a matrix.

iii. Encapsulation or sealing of acms in good condition.

iv. Air monitoring and control task or collecting and analysing samples to establish whether a specific material contains asbestos.

3.3.4 Non-licensable work will be notifiable except where the asbestos material is not friable and works being carried out includes maintenance, removal, encapsulation, air monitoring, control or collection and analysis of samples.

3.3.5 The anticipated phasing timeline of the planned activities during the works are set out in **Table 1**. Some of the activities during each phase will disturb the ground, which could potentially mobilise asbestos fibres.

3.3.6 The Control of Asbestos Regulations 2012 - Interpretation for Managing and Working with Asbestos in Soil and Construction and Demolition Materials: Industry guidance (Ref 1-3), presents a decision flowchart to assist in determining when work on soil or construction and demolition materials contaminated by asbestos is likely to be non-licensed work or notifiable work (see **Plate 1**).

3.3.7 In addition, any workers working in an area where asbestos may be present must be Asbestos Awareness trained as a minimum, and depending on the role they are to undertake further levels of training may be required in line with CAR 2012 (Ref 1-13) and appropriate measures must be used to eliminate asbestos exposure or reduce it to as low as is reasonably practicable.

Plate 1: Non-Licensed Works Decision Flow Chart

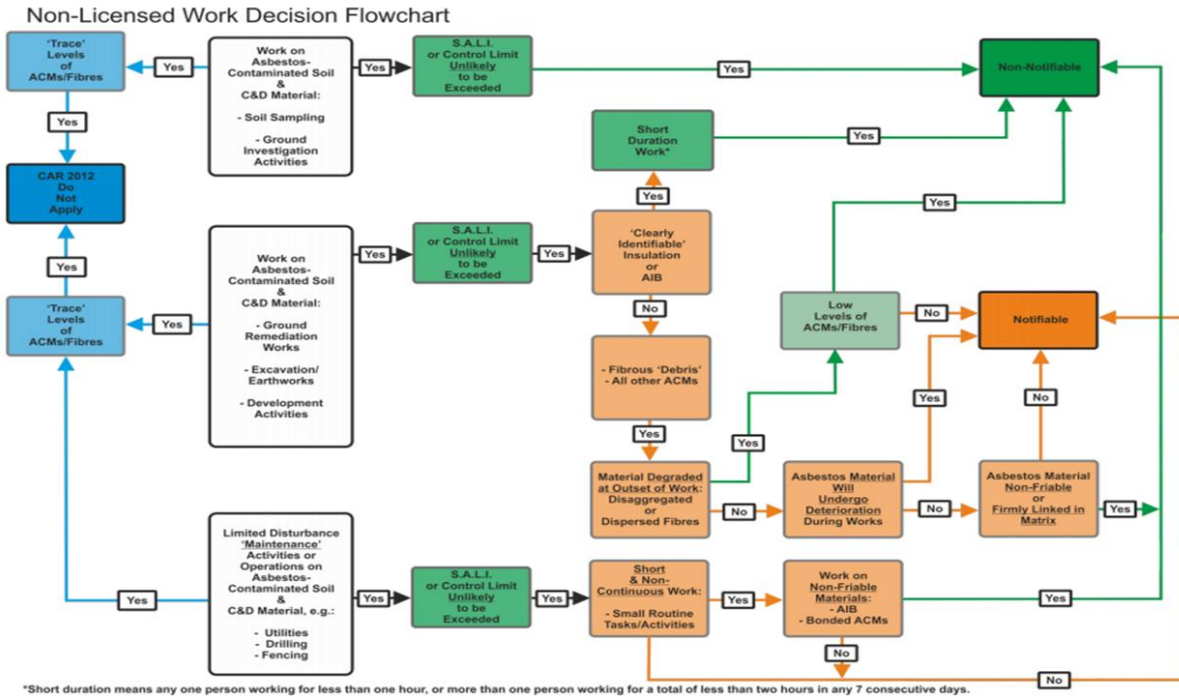

4 Asbestos Work Procedures

4.1 General

- 4.1.1 This section has been prepared in accordance with the CAR 2012 (Ref 1-13) regulations and it describes the procedures and possible methodologies to be used by contractors and construction workers during the excavation, handling and disposal or placement of potential asbestos containing materials identified during the works for the Project.
- 4.1.2 The works within the East Site are not considered to require an asbestos license and are not considered notifiable. However, precautions should be taken throughout the works to prevent health impacts should ACMs be encountered during the works. The contractor must be informed of the potential for ACM to be present especially in the East Site. The contractor must develop their own Site-specific Risk Assessment and Method Statement in addition to this AMP, which must be adhered to by all site personnel.
- 4.1.3 Through the required training process, all site personnel are to be educated regarding the potential risks associated with asbestos containing materials which may be encountered on the surface or in excavated Made Ground. The information to be provided during the training sessions should include identification of friable and non-friable asbestos (examples to be provided), awareness of hazard associated with asbestos, emergency procedures and proper storage and disposal of asbestos material.
- 4.1.4 During site induction, all site personnel are to be made aware of the procedures (see **Plate 2**) that should be adhered to should suspected asbestos containing materials be identified at the site.

4.2 Plan of Work

- 4.2.1 Regulation 7 of the CAR 2012 (Ref 1-13) requires that a written Plan of Work be prepared as part of the Final AMP(s) (Incorporated into Final CEMP(s)) prior to the commencement of works at the Site. The Plan of Work should contain the information regarding:
- a. The nature and probable duration of the work.
 - b. The number of people involved in the work.
 - c. The work address, location and site layout with a description of where and nature of acm that may be encountered.
 - d. The methods to be used to prevent or reduce exposure to asbestos, e.g. Prevention and control measures and arrangements for the handling and disposal of asbestos waste.
 - e. The type of equipment, including ppe and rpe, used for:
 - i. Protecting and decontaminating those carrying out the work.
 - ii. Protecting other people present at or near the worksite.

4.3 Asbestos Management Procedures

Demarcation of Exclusion Zones

- 4.3.1 Exclusion zones are not currently considered necessary. However, should ACM be encountered the following should be undertaken; where work is to be undertaken in areas with asbestos contamination, these areas must be demarcated, and access must be restricted to authorised personnel with appropriate PPE (see **Section 5.1**).
- 4.3.2 When leaving the exclusion zone, all personnel, vehicles and equipment must be decontaminated. The decontamination area should be located between the exclusion zone and the ‘clean’ area outside the exclusion zone.
- 4.3.3 The demarcated areas must be clearly and appropriately signed and shown on the site plan and the details passed on to all site personnel and visitors during induction and toolbox talks.

Prevention and Suppression of Asbestos Release

- 4.3.4 Activities such as excavation that can potentially disturb and release asbestos fibres cannot be avoided during the construction works. However, careful planning and design of works will ensure that all necessary and unavoidable disturbance and material movements will be carried out with care. Activities such as dropping of objects or materials from height will be avoided.
- 4.3.5 Prior to the commencement of any activity that can result in the release of asbestos fibres, the ground or structure should be damped down using water to prevent the release of potentially contaminated air-borne dust. Preparation will be made for adequate water supply using a low-pressure spray connected to a mains or a bowser. The use of high-pressure spray must be avoided as it can disturb and release asbestos fibres in the air. Care must be taken to keep the ground damp enough to prevent the release of asbestos fibres, but not too excessive to cause a slurry.
- 4.3.6 During excavation and loading activities, dust emissions from the excavation face and trucks being loaded are to be suppressed at all times using low-pressure water spray or other suitable dust suppression technique.
- 4.3.7 Excavator operator and truck drivers are to work in an enclosed cabin with windows closed and movements outside of the cabin to be reduced to a minimum. The designated vehicle routes must also be damped down and vehicles must travel at a restricted low speed limit.
- 4.3.8 All site personnel in the work area are to wear appropriate personal protective equipment (“PPE”).

Asbestos Containing Materials at the Surface

- 4.3.9 Regulation 24 of the CAR 2012 (Ref 1-13) requires that any detected raw asbestos and asbestos waste is properly packaged, labelled, stored and transported. Handling of asbestos containing materials to be undertaken by a competent person.

- 4.3.10 Where limited quantities of ACMs (i.e. asbestos fragments/sheets or any fibrous asbestos) are identified or suspected at the surface of the Site, precautions to prevent fibre release should be taken. The ACMs should be securely sealed and double-bagged in suitable, labelled bags or wrapping. The bags used must be designed to ensure that no asbestos fibres can be released during handling and transport. Stronger packages will be required if the waste contains sharp metal fragments or materials that could puncture the bags.
- 4.3.11 It is recommended that large items of rigid ACM such as sheets of asbestos cement should not be broken up or cut down for disposal in bags. The intact rigid waste should be double wrapped in suitable polythene sheeting (1000 gauge) or other suitable material and labelled accordingly.
- 4.3.12 If the asbestos waste is not disposed of immediately, the sealed bags or wrapped packages (for large rigid ACMs) should be locked in a suitable and clearly marked storage area, i.e. a lockable skip or freight container.

Asbestos Containing Materials in Excavated Ground

- 4.3.13 Any excavation works within the Made Ground at the Site during the works shall be under supervision of a suitably 'competent person' to visually check for the presence of potential ACM. A competent person should possess adequate qualifications, such as suitable training and sufficient knowledge, experience and skill for the safe performance of the proposed works.
- 4.3.14 Encountered ACM in Made Ground during the excavation should be quarantined at first and stored with suitable sheets or geofabric covering pending asbestos assessments. Representative samples of the Made Ground should be obtained by a competent person and sent to the laboratory for asbestos identification and quantification (if asbestos is identified). For Made Ground a representative sample is one per 100m³ of excavated material (or a minimum of three samples from any one source area).
- 4.3.15 The procedure to be followed in the event of asbestos being detected in the Made Ground is shown in **Plate 2**. The primary response should be to avoid any further disturbance of the material and prevent access to the stockpile area by the placement of barricades. If the material appears friable or there is a risk of further disturbance from the weather such as high winds the material may be dampened down and covered with heavy gauge polythene or geo-fabric either of which should then be properly secured warning signs should be put in place and the discovery should be included in any daily toolbox talks.
- 4.3.16 In the unlikely event of there being large volumes of excavated waste contaminated by asbestos, it may not be practicable to place material into plastic bags or bulk packaging. Consideration may be given to the placement of material directly into an appropriate pre-lined bulk container such as a haulage vehicle or a roll-on, roll-off skip. Procedures should be in place to minimise the spread of asbestos during the loading operation and to prevent spread from the load while it is being transported on the road. Consideration should also be given to how unlined bulk containers are cleaned to ensure that the spread of asbestos is minimised.

Transportation and Disposal of Asbestos Waste

- 4.3.17 The strategy for the contained transport of waste material to landfill should be considered based on the type and volume of waste and agreed with relevant stakeholders, including the client, the regulator (for waste) and the landfill operator. Transportation and disposal will be undertaken by specialist registered contractor in accordance with the specific requirements of the Hazardous Waste (England and Wales) (Amendment) Regulations (Ref 1-14).
- 4.3.18 Bags, wrapping or packaging containing asbestos waste should be appropriately labelled and transported directly to a suitably permitted disposal site. Wherever possible and practical, asbestos-contaminated waste should be transported in an enclosed vehicle, skip or freight container. In all circumstances, a suitable receptacle should be used to transport bagged or wrapped asbestos waste to make sure that the bags and packaging cannot become damaged or open up and release asbestos material or asbestos fibres during transit. Similarly, bulk containers into which bulk excavated waste materials are loaded should be capable of being transported in a manner that eliminates the spread of asbestos.
- 4.3.19 All incidents concerning the uncovering of suspected ACM are to be dealt with and recorded in accordance with the HSE regulations. The record should include:
- a. Date and time of detection.
 - b. Nature and description of the ACM.
 - c. Response action taken and date of action.
- 4.3.20 Once the material has been confirmed as containing asbestos the material may be removed by an Asbestos Removal Contractor or the signs taken down if it is confirmed as non-asbestos.

Plate 2: Procedure of Uncovering Suspected Asbestos Materials and Emergencies

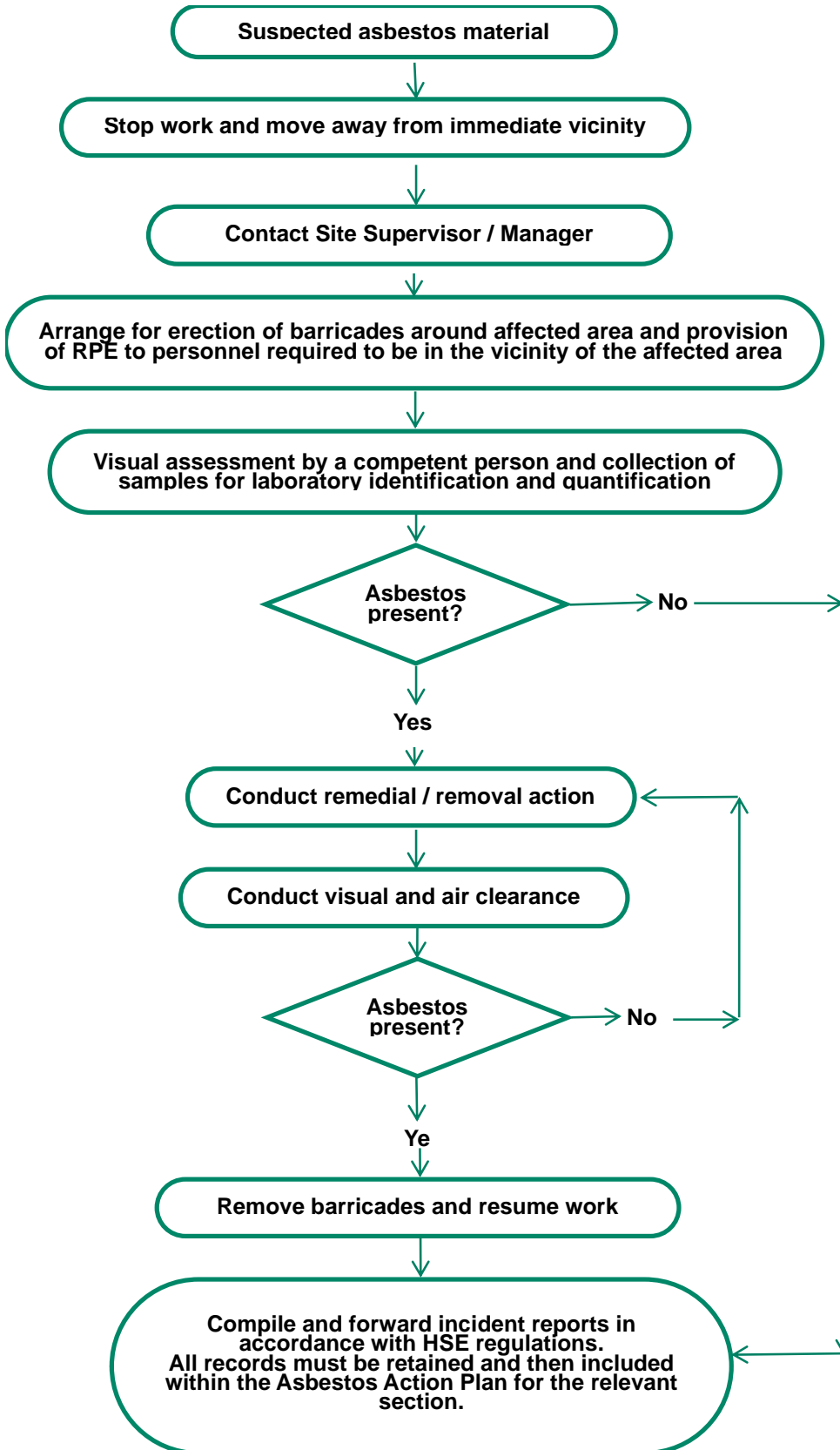

5 Asbestos Working Requirements

5.1 Training Requirements

- 5.1.1 All relevant site personnel involved in works where there is deemed to be risk of exposure to asbestos will be required to undergo a mandatory Asbestos Awareness training prior to the commencement of the works.
- 5.1.2 The personnel must have completed the appropriate training on the types of asbestos material and their uses, asbestos legislation, identification and health effects. All training certificates must be kept on site with the Site Manager and must be made available for inspection on request.
- 5.1.3 All site personnel must also undergo the site induction and daily toolbox talks, where information on asbestos as relevant to each working area will be disseminated.
- 5.1.4 All contractors must take into account the information in this document, while preparing their risk assessment and method statements (“RAMS”). Contractors must ensure that their staff have read, understood and signed the RAMS prior to the commencement of the works.

Personal Protective Equipment

- 5.1.5 PPE must be worn by all workers, supervisors and visitors present within areas of suspected asbestos contamination. The required PPE will include:
 - a. Hi-visibility clothing.
 - b. Type 5/6 disposable coveralls.
 - c. Hard hat.
 - d. Safety wellington boots.
 - e. FFP3 face mask.
 - f. Gloves.
 - g. Ear protection.
- 5.1.6 Note that all personnel wearing FFP3 half-face masks must have undergone a suitable face-fit test for the mask and must only wear the make/model/size of mask stated in their face-fit certificate. All those wearing masks must be clean-shaven.
- 5.1.7 Personnel must decontaminate every time they leave the dirty area to move into a clean area, even if just for a short time. Personnel must be trained on the decontamination procedure prior to the project commencing.
- 5.1.8 PPE that cannot be thoroughly decontaminated must be disposed of as asbestos waste.
- 5.1.9 Note that PPE is the last line of defence and all other control measures detailed in Section 4 above must be put in into place prior to reliance on PPE.

6 References

- Ref 1-1 AECOM. (2022). Immingham NH3 Project Development Appraisal Report. 60673509-GTN-DAR-001. Revision 00.
- Ref 1-2 AECOM 2022AECOM. (2023). Immingham Ammonia Import Terminal. Ground Investigation Report. Air Products PLC. 60687114.
- Ref 1-3 CL:AIRE. (2012). Control of Asbestos Regulations 2012 - Interpretation for Managing and Working with Asbestos in Soil and Construction and Demolition Materials: Industry guidance.
- Ref 1-4 Geotechnical Engineering Limited. (2023). AP Ammonia Import Terminal. Factual Ground Investigation Report. 37312.
- Ref 1-5 Health and Safety Executive. (1974). Health and Safety at Work etc Act.
- Ref 1-6 Health and Safety Executive. (2012). Asbestos Essentials - Advice on Non-Licensed Work with Asbestos.
- Ref 1-7 Health and Safety Executive. (2012). Asbestos: The Licensed Contractors' Guide HSG247.
- Ref 1-8 Health and Safety Executive. (2013). Managing and Working with Asbestos. Control of Asbestos Regulations 2012 - Approved Code of Practice and Guidance.
- Ref 1-9 Health and Safety Executive. (2023, July 21). Asbestos Health and Safety. Retrieved from www.hse.gov.uk/asbestos/index.htm
- Ref 1-10 UK Public General Acts. (1990). Environmental Protection Act.
- Ref 1-11 UK Statutory Instruments . (2015). The Construction (Design and Management) Regulations.
- Ref 1-12 UK Statutory Instruments. (1991). The Environmental Protection (Duty of Care) Regulations.
- Ref 1-13 UK Statutory Instruments. (2012). The Control of Asbestos Regulations .
- Ref 1-14 UK Statutory Instruments. (2016). The Hazardous Waste (England and Wales) (Amendment) Regulations.

Appendix F: Outline Water Vole Precautionary Working Method Statement



Immingham Green Energy Terminal

TR030008

Volume 6

Appendix F – Outline Water Vole Precautionary
Working Method Statement

Planning Act 2008

Regulation 5(2)(a)

Infrastructure Planning (Applications: Prescribed
Forms and Procedure) Regulations 2009 (as
amended)

September 2023

Infrastructure Planning

Planning Act 2008

The Infrastructure Planning
(Applications: Prescribed Forms and
Procedure) Regulations 2009 (as amended)

Immingham Green Energy Terminal Development Consent Order 2023

Appendix F – Outline Water Vole PWMS

Regulation Reference	APFP Regulation 5(2)(a)
Planning Inspectorate Case Reference	TR030008
Application Document Reference	TR030008/APP/6.5
Author	Associated British Ports Air Products BR

Version	Date	Status of Version
Revision 1	21 September 2023	DCO Application

Table of contents

1	Introduction	1
1.1	Background and Scope	1
1.2	Precautionary Working Method Statement.....	1

1 Introduction

1.1 Background and Scope

1.1.1 This Outline Water Vole Precautionary Working Method Statement (“PWMS”) (**Table 1**) sets out the proposed procedures and practises to be implemented during the construction works for the Project to ensure compliance with a Natural England Water Vole Class Licence.

1.1.2 This PWMS relates only to works undertaken on Ditch 5 (**Work No. 1**) as this is the only ditch impacted by the Project that supports water vole (*Arvicola amphibious*).

1.1.3 A small population of water vole was recorded in Ditch 5 during surveys undertaken for the Project in 2022. The results of the surveys are reported in **Appendix 8.D: Otter and Water Vole Report** of the Environmental Statement [TR030008/APP/6.4].

1.2 Precautionary Working Method Statement

Table 1: Water Vole Draft Precautionary Working Method Statement

Water Vole: Draft Precautionary Working Method Statement		
Action	Rationale	Responsibility
<p>Toolbox Talk</p> <p>All site personnel would be briefed as to the legislative protection afforded to water vole at a toolbox talk prior to commencing works.</p> <p>All site personnel would sign a Toolbox Talk attendance sheet prior to commencing works.</p>	Awareness	Contractor’s appointed Water Vole Class Licensed Ecologist
<p>Water Vole Survey Prior to Vegetation Removal</p> <p>Prior to commencement of vegetation cutting on Ditch 5 (Works No. 1), a survey would be undertaken by an ecologist to identify water vole burrows. These locations would be recorded and marked on site.</p>	Legislative compliance	Contractor’s appointed Water Vole Class Licensed Ecologist
<p>Water Vole Displacement under Class Licence</p> <p>Vegetation removal on Ditch 5 would be undertaken under the supervision of the Water Vole Class Licensed Ecologist.</p> <p>Vegetation removal from the affected section of Ditch 5 (and therefore water vole displacement) would be undertaken between 15 February and 15 April and/or 15 September to 31 October.</p>	Avoidance of accidental killing/ injury	Contractor and Contractor’s appointed Water Vole Class Licensed Ecologist

Water Vole: Draft Precautionary Working Method Statement		
Action	Rationale	Responsibility
<p>Bankside vegetation removal would not exceed 50 m in length on each bank.</p> <p>All vegetation on the bank face and a buffer of up to 10 m (where necessary) would be cleared. Any emergent aquatic vegetation within the channel would also be cleared.</p> <p>Cut vegetation and arisings would be removed from site.</p>		
<p>Habitat Management Prior to Commencement of Construction</p> <p>Any bankside vegetation re-growth on Ditch 5 would be removed, and the bankside habitat kept short (vegetation height no greater than 10 cm) to ensure continued displacement of water voles prior to the commencement of construction.</p> <p>Habitat maintenance within the cleared zone can be undertaken at any time of year and is not restricted to the periods set out above (which relate only to initial clearance of habitat/ displacement of water voles).</p> <p>Cut vegetation and arisings would be removed from site.</p>	Legislative compliance	Contractor and Contractor's appointed Water Vole Class Licensed Ecologist
<p>Destructive Search Prior to Commencement of Construction</p> <p>A destructive search would be undertaken under the supervision of the Water Vole Class Licensed Ecologist between 5 and 10 days after vegetation removal.</p> <p>Prior to commencement of a destructive search, the cut area would be surveyed for the presence of water vole field signs.</p> <p>Where evidence indicates the continued presence of water voles in burrows, each burrow would be carefully excavated and searched, and destroyed once the search completed.</p>	Avoidance of accidental killing/ injury	Contractor and Contractor's appointed Water Vole Class Licensed Ecologist
<p>Water Vole Discovery</p> <p>Any water voles found during the destructive search would be either allowed to escape to unaffected sections of Ditch 5, or would be captured and kept in a suitable animal container before being immediately released into unaffected sections of Ditch 5.</p> <p>Animals would not be kept in containers for longer than is necessary to relocate them to a place of safety.</p>	Legislative compliance	Contractor's appointed Water Vole Class Licensed Ecologist

Water Vole: Draft Precautionary Working Method Statement		
Action	Rationale	Responsibility
<p>Construction</p> <p>Works would commence within 5 days of completing the destructive search.</p> <p>If this is not possible, the channel would either be immediately in-filled or the banks maintained as bare ground until the construction work commences.</p> <p>This would ensure that there is no re-establishment of water voles prior to commencement of works.</p> <p>Appropriate monitoring would be undertaken of the habitat for signs of water vole prior to commencement of construction.</p>	Legislative compliance	Contractor
<p>Temporary Construction Area Buffer Zone</p> <p>A clearly marked buffer zone of at least 10 m from the top of the ditches adjacent to the Temporary Construction Area (Work No. 9) would be established to protect the watercourses from accidental damage and disturbance during construction.</p>	Legislative compliance	Contractor

Appendix G: Outline Badger Precautionary Working Method Statement



Immingham Green Energy Terminal

TR030008

Volume 6

Appendix G – Outline Badger Precautionary Working
Method Statement

Planning Act 2008

Regulation 5(2)(a)

Infrastructure Planning (Applications: Prescribed
Forms and Procedure) Regulations 2009 (as
amended)

September 2023

Infrastructure Planning

Planning Act 2008

The Infrastructure Planning
(Applications: Prescribed Forms and
Procedure) Regulations 2009 (as amended)

Immingham Green Energy Terminal Development Consent Order 2023

Appendix G – Outline Badger PWMS

Regulation Reference	APFP Regulation 5(2)(a)
Planning Inspectorate Case Reference	TR030008
Application Document Reference	TR030008/APP/6.5
Author	Associated British Ports Air Products BR

Version	Date	Status of Version
Revision 1	21 September 2023	DCO Application

Table of contents

1	Introduction	1
1.1	Background and Scope	1
1.2	Legislation	1
1.3	Precautionary Working Method Statement.....	2

1 Introduction

1.1 Background and Scope

- 1.1.1 This Outline Badger Precautionary Working Method Statement (“PWMS”) (Table 1) sets out the proposed procedures and practises to be implemented during the construction works for the Project to address the low risk of encountering badger (*Meles meles*) during construction.
- 1.1.2 This draft PWMS relates to any vegetation clearance of dense scrub within the Project area.
- 1.1.3 No evidence of badger was identified within the Project area during ecology surveys undertaken for the Project, and it was concluded that badger was likely absent from the Project area. However, the low risk of badger setts being present within areas of dense scrub that could not be accessed during surveys could not be ruled out. This risk was evaluated in **Appendix 8.B: Preliminary Ecological Appraisal Report** of the Environmental Statement [TR030008/APP/6.4], where it was identified that appropriate precautionary working methods would be sufficient to address any low residual risk of encountering badger setts.

1.2 Legislation

- 1.1.4 Badgers and their setts are protected under the Protection of Badgers Act 1992 (as amended). This makes it an offence to wilfully kill, injure or take a badger; or intentionally or recklessly damage, destroy or obstruct access to a badger sett or disturb a badger in its sett.
- 1.1.5 It is not illegal to carry out disturbance activities near setts that are not occupied, i.e. those that do not show signs of current use.
- 1.1.6 Where required, licences for development activities involving disturbance or sett interference or closure are issued by Natural England. Licences for activities involving watercourse maintenance, drainage works or flood defences are issued under a separate process.
- 1.1.7 When assessing the requirement for a licence in respect of development, Natural England¹ state that badgers are relatively tolerant of moderate levels of noise and activity around their setts, and that a low or moderate level of apparent disturbing activity at or near to badger setts does not necessarily disturb the badgers occupying those setts.
- 1.1.8 Licences are normally not granted from December to June inclusive (the badger breeding season) because dependent cubs may be present within setts.

¹ Interpretation of ‘Disturbance’ in relation to badgers occupying a sett.

1.3 Precautionary Working Method Statement

Table 1: Draft Badger Precautionary Working Method Statement

Badgers: Draft Precautionary Working Method Statement		
Action	Rationale	Responsibility
<p>Toolbox Talk</p> <p>All site personnel would be briefed as to the legislative protection afforded to badgers at a toolbox talk prior to commencing works.</p> <p>All site personnel would sign a Toolbox Talk attendance sheet prior to commencing works.</p>	Awareness	Contractor
<p>Pre-construction Ecology Walkover</p> <p>A pre-construction walkover would be undertaken by an ecologist to check whether any badger setts are present in the working area.</p>	Avoidance of damage/ disturbance to setts	Contractor's appointed Ecologist
<p>Sensitive Vegetation Clearance</p> <p>If areas of dense vegetation cannot be checked for the presence of badger setts prior to commencement of works, vegetation clearance would be undertaken under ecological supervision.</p>	Avoidance of damage/ disturbance to setts	Contractor's appointed Ecologist
<p>Badger Sett Discovery</p> <p>In the event of a badger sett discovery, work would stop temporarily, and an ecologist would be contacted for advice.</p>	Avoidance of accidental killing/ injury	Contractor
<p>Badger Licence</p> <p>If active badger setts are identified and cannot be avoided through a 30m offset, a licence will be obtained from Natural England to close the sett.</p>	Legislative compliance	Client
<p>Licensed Sett Closure</p> <p>Once a Natural England licence has been obtained, sett closure will be undertaken under the supervision of a licensed ecologist.</p> <p>Sett closures under licence are seasonally constrained to the period between July and November inclusive.</p>	Legislative compliance	Contractor and Contractor's appointed Ecologist